

CDI-SURETEST

Model 5000-ST



USER'S MANUAL

TABLE OF CONTENTS

<i>Safety Information</i>	I
<i>Introduction</i>	1-1
<i>Functional Description and Specifications</i>	2-1
Functional Descriptions	2-1
<i>SURETEST</i> Torque Calibration System	2-1
Roll cabinet	2-2
Front Panel	2-3
Rear Panel (Input/Output)	2-9
Torque Transducers	2-11
Specifications	2-12
<i>SURETEST</i> Torque Calibration System	2-12
Manual loader specifications	2-14
<i>Setup and Programming</i>	3-1
<i>SURETEST</i> Torque Calibration System Setup	3-1
Setting Up the <i>Suretest</i> System	3-2
<i>Suretest</i> Controls	3-3
Powering the Equipment	3-3
4-in-1 Transducer Select	3-4
Programming Setup	3-5
Setting up Date and Time	3-5
Setting Up High and Low Limits Alert	3-5
Programming AUTO CLEAR	3-6
DATA LIST Memory	3-7
Setting Up Printer/PC Ports	3-8
Selecting Printer/PC Ports	3-8
Setting Up Serial Communications	3-8
<i>Torque Calibration System Setup</i>	4-1
Testing Torque Wrenches and Drivers	4-1
Selecting a Transducer	4-1
Installing a Transducer	4-1
Dial and Bending Beam Torque Wrenches and Screwdrivers	4-2
Adjustable or Preset “Click” Wrenches and Screwdrivers	4-3
Testing Power Tools	4-4
Non-Impact Tools	4-4
Displaying Statistical Analysis	4-7
Displaying Statistical Analysis on LCD	4-7
Printing Statistical Analysis	4-8
Displaying or Downloading Data List	4-10
Displaying Data List on LCD	4-10
Downloading Data List to Printer	4-10
How to Use Analog Output (Rear Panel BNC Connector)	4-11
<i>Calibration</i>	5-1
Mounting Details	5-1
Quick Check	5-4
Torque Transducer Calibration	5-7

<i>Suretest</i> Indicator Torque Calibration	5-11
Gravitational Effects	5-14
Correction Factors on Test Weights	5-14
Gravitational Charts	5-14
<i>2000-600-02 Manual Loader</i>	6-1
Application	6-1
Torque Tester/Calibrator	6-2
2000-600-02 Manual Loader	6-3
Loader Rear Panel Controls	6-5
Ball Handle Adaptor	6-6
4-in-1 Transducer (Accessory)	6-7
Extension Arm (Accessory)	6-8
Types of Loader Testing	6-9
Torque Driver Testing	6-9
Torque Multiplier Testing	6-9
<i>Accessories</i>	A-1
<i>SURETEST</i> System Components and Inventory Control	A-2
Optional Transducers and Accessories	A-3
Calibration Accessories	A-5

Using this Manual

This manual contains instructions for use and setup of the **Suretest** Torque Calibration System. A table of contents and a table of illustrations are provided to make this manual easy to use.

Some of the information shown in text or illustrations is obtained using optional equipment.

Conventions

This section contains a list of conventions used in text.

Chapter References

Additional information in text is referenced by chapter number and section name.

Example:

For testing procedures refer to Chapter 4—Using the **SURETEST** System.

Equipment Damage

The possibility of damage to vehicle or equipment is introduced by a signal word indicating this condition.

Example:

IMPORTANT

The connector on single transducer cables contains the EEPROM calibration memory chip. Never attempt to remove the connector from the transducer. It is installed with a permanent adhesive.

Safety Messages

Safety messages are provided to help prevent personal injury and equipment damage. All safety messages are introduced by a signal word indicating the hazard level. The types of safety messages are: Danger, Warning and Caution.

DANGER

Indicates an imminently hazardous situation which, if not avoided, will result in death or serious injury to the operator or to bystanders.

WARNING

Indicates a potential hazard which, if not avoided, could result in death or serious injury to the operator or to bystanders.

CAUTION

Indicates a potential hazard which, if not avoided, may result in minor or moderate injury to the operator or to bystanders.

The three-part message panel, used with safety messages, uses three different type styles to further define the potential hazard:

- Normal type states the hazard,
- **Bold type** states how to avoid the hazard, and Warning.
- Italic type states the possible consequences of not avoiding the hazard.

Some safety messages contain visual symbols with signal words.

Example:

WARNING

Flying particles can discharge when applying torque.

- *Users and bystanders must wear safety goggles.*
- *Always wear safety goggles when applying torque.*

Flying particles can cause injury.

Safety Information

Important Safety Instructions

This manual contains important safety and operating instructions for CDI *SURETEST* Torque calibration system. Refer to the information in this manual often for safe operation.

Read All Instructions

Read, understand and follow all safety messages and instructions in this manual and on the test equipment. Safety messages in this section of the manual contain a signal word, a three-part message.

The signal word indicates the level of hazard in a situation:

- **Danger** indicates an imminently hazardous situation which, if not avoided, will result in death or serious injury to the operator or bystanders.
- **Warning** indicates a potentially hazardous situation which, if not avoided, could result in death or serious injury to the operator or bystanders.
- **Caution** indicates a potentially hazardous situation which, if not avoided, may result in moderate or minor injury to the operator or bystanders.

The three-part message uses three different type styles to further define the potential hazard.

- Normal type states the hazard.
- Bold type states how to avoid the hazard.
- Italic type states the possible consequences of not avoiding the hazard.

SAVE THESE INSTRUCTIONS

WARNING

Risk of electric shock and fire.

- For indoor use only. Do not expose charger to rain or snow. Do not use in damp locations.
- Replace defective cord immediately. Return to qualified service center for replacement. Electric shock or fire can cause injury.

WARNING

Flying particles can discharge when applying torque.

- Users and bystanders must wear safety goggles.
- Always wear safety goggles when applying torque.
- Do not use this equipment with the power off. Always turn on the indicator and loader so the torque and load values are indicated on the display. The safety relays only work when the power is on. Flying particles can cause injury.

WARNING

Risk of entanglement.

- When starting power tools, check for obstacles near your hand and anticipate the reaction force by gripping the tool firmly.
- Do not wear loose clothing and jewelry while operating a power tool. Loose clothes and jewelry can be caught in moving parts.
- Keep body parts away from rotating parts.
- Wear a protective hair covering to contain long hair and prevent contact with moving parts.
- Do not overreach. Keep proper footing and balance at all times.
Entanglement can cause injury.

WARNING

Improper use can cause breakage.

- Read instructions before operating.
- Follow manufacturer's instructions, safety precautions, and specifications when operating tools. Broken equipment can cause injury.

WARNING

- Make sure all components, including, adaptors, extensions, drivers and sockets are rated to match or exceed the torque or load being applied.
- Be sure the capacity of the **SURETEST** system matches or exceeds each application before performing a procedure.
- Do not use the **SURETEST** system if it makes unusual noises, has loose parts, or shows any other sign of damage. Have repairs performed at an Authorized Service Center before use.
- Do not use chipped, cracked, or damaged sockets and accessories.
- Do not remove any labels. Replace any damaged label.
- Follow good, professional tool practices:
** *Pull on a wrench handle* ** **do not push** ** and adjust stance to prevent a possible fall.
** **Do not use extensions**, such as a pipe, on a wrench handle.
- When using ratchets, make sure the direction lever is fully engaged in the correct position.
- Never attempt to test an impact tool on this instrument.
- Always position the 40" arm over the front of the stand as shown. Never extend the test arm behind the stand. The stand will tip over when weights are applied.
- Always be alert to the potential for personal injury that may be caused by excessive torque applications, careless handling of heavy weights, and out-of-balance or unsafe weight distribution.

PRODUCT DESCRIPTION

CDI-SURETEST MODEL 5000-ST

The *SURETEST* is a laboratory grade instrument that provides TORQUE measurements. Although designed as an independent laboratory equipment, it can also be used in an integrated environment as the principal component of a Torque Calibration System. The *SURETEST* features versatile data acquisition capabilities including measurement storage, retrieval, statistical analysis and automatic downloading to an external printer/computer. A remote computer COM port is available for PC interfacing.

Used with precision torque transducers, the *SURETEST* provides high speed monitoring of static or dynamic torque inputs. Torque/force transducers, purchased separately, are available in ranges from 15-200 in- oz, to 200-2000 ft-lb, and provide system readings with an accuracy of +/- 0.25% of indicated value, or better. A special memory chip is built into each torque/force transducer that identifies its range and maintains its calibration between any other *SURETEST* with an accuracy of +/- 0.5%. The *SURETEST* and its transducers may be calibrated by using accessory precision bars and certified weights.

All readout of torque in ft-lb, in-lb, in-oz, Nm, dNm, cNm, mkg as well as calibration, statistical analysis and set-up functions are reported on a versatile 1.5" x 5.5" graphic dot matrix Liquid Crystal Display (LCD).

Set-up and calibration programming is entered using easy-to-use front panel membrane keys. The number of keys is kept to a minimum. In addition, concise menus and graphic symbols are used to guide the user through all set-ups and operations. HIGH and LOW torque limits are adjustable to give an audible alert. The user selects TRACK mode to display torque values as they are applied, PEAK HOLD or POWER TOOL modes to display the highest torque value applied, or FIRST PEAK mode which captures the torque output at the "click" of a set-able wrench or driver. CLEAR, STORE and SEND functions can be set up for automatic or manual operation.

The *SURETEST* stores and recalls up to 3000 torque readings and does statistical analysis on them for downloading to printer or computer. The statistical report (print out) includes a simple histogram for process monitoring. True RS-232 serial printer and separate RS-232 computer COM ports are at the back of the unit

CHAPTER 1

Introduction

The *SURETEST* is a laboratory grade instrument that provides TORQUE measurements. Although designed as an independent digital indicator, it can also be used in an integrated environment as the principal component of a Torque Calibration System. The *SURETEST* features versatile data acquisition capabilities including measurement storage, retrieval, statistical analysis and automatic downloading to an external printer/computer. A remote computer COM port is available for PC interfacing.

Used with precision torque transducers, the *SURETEST* provides high speed monitoring of static or dynamic torque inputs. Torque transducers, purchased separately, are available in ranges from 15-200 in- oz, to 200-2000 ft-lb, and provide system readings with an accuracy of $\pm 0.25\%$ of indicated value, or better. A special memory chip is built into each torque transducer that identifies its range and maintains its calibration between any other *SURETEST* with an accuracy of $\pm 0.5\%$. The *SURETEST* and its transducers may be calibrated by using accessory precision bars and certified weights.

All readout of torque in ft-lb, in-lb, in-oz, Nm, dNm, cNm, mkg as well as calibration, statistical analysis and set-up functions are reported on a versatile 1.5" x 5.5" graphic dot matrix Liquid Crystal Display (LCD).

Set-up and calibration programming is entered using easy-to-use front panel membrane keys. The number of keys is kept to a minimum. In addition, concise menus and graphic symbols are used to guide the user through all set-ups and operations. HIGH and LOW torque limits are adjustable to give an audible alert. The user selects TRACK mode to display torque values as they are applied, PEAK HOLD or POWER TOOL modes to display the highest torque value applied, or FIRST PEAK mode which captures the torque output at the "click" of a set-able wrench or driver. CLEAR, STORE and SEND functions can be set up for automatic or manual operation.

The *SURETEST* stores and recalls up to 3000 torque readings and does statistical analysis on them for downloading to printer or computer. The statistical report (print out) includes a simple histogram for process monitoring. True RS-232 serial printer and separate RS-232 computer COM ports are at the back of the unit.

The *SURETEST* operates directly from any AC power line between 120VAC to 220 VAC, 50–60 Hz without the need for switch selection. A hard-wired lithium battery keeps the internal memory and date-time clock operating for up to 10 years. The real time clock is fully year 2000 compliant.

The information in this manual is general. Operational features, procedures and specifications may change without notice. CDI makes no claims as to the suitability of this information for diverse user applications.

CHAPTER 2

Functional Descriptions and Specifications

The *SURETEST* is CDI's next generation Torque Measurement System. It provides exceptional accuracy and ease of use. It is packaged in a compact, sturdy and attractive housing unit which requires little room on a laboratory bench. The *SURETEST* is typically used in conjunction with a Transducer and a Mechanical Loader.



Fig 2-1

Base Unit

The *SURETEST* monitors and displays the torque applied.

Transducer (Accessory)

The loader accepts all *SURETEST* series single transducers directly. Use a 2000-500-02 adapter kit to mount the optional 2000-400-02 4-in-1 transducer. For additional information refer to Appendix A–Accessories.

Loader

Use the 2000-600-02 Manual Loader for testing and calibrating all torque wrenches, drivers, torque multipliers, non-impact pneumatic and electric nut runners. Loader components are:

- Stand For Base Unit
- Safety Shield
- Hand Crank
- Transducer Mounting

Roll Cabinet

The roll cabinet features nine heavy duty drawers with ball bearing slides, locking wheels and drawer locks. *SURETEST* accessories are stored in the roll cabinet which is fitted with foam inserts for easy inventory control. The nine drawers are assigned and arranged as shown in figure A-1 of Appendix A.

***SURETEST* Base Unit**

This section describes the major hardware components of the *SURETEST* Base Unit, including:

- Front Panel
- Rear Panel (Input/Output)
- *SURETEST* Torque Transducers.

FRONT PANEL

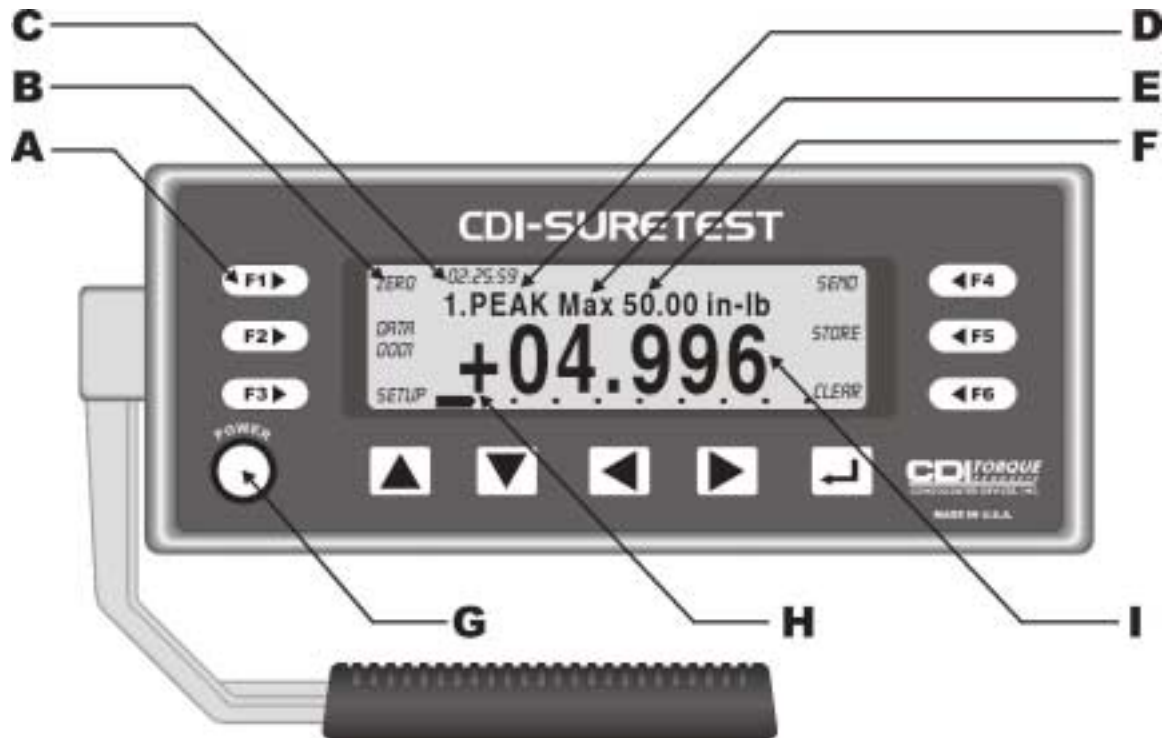
Figure 2-3: *SURETEST* Front Panel

- A- **Membrane Function** (F1, F2, F3, F4, F5, F6),
And **Cursor/Selection** (Up, Down, Left, Right and Enter) **Keys**.
- B- **Soft Key Menu:** Zero, # Data Stored, Setup, Send, Store, Clear, Escape, Format.
- C- **Real Time Clock.** HH:MM:SS
- D- **Modes:** Track, Peak Hold, First Peak and Power tools.
- E- **Maximum Range** of Transducer.
- F- **Engineering Units** : Nm, dNm, Ncm, mkg, cmkg, ft.lb, in.lb, in.oz
- G- **Power:** On/Off
- H- **Scroll Bar** Each dot represents 10% of Full scale.
- I- **Torque Reading:** Full 5-digit reading Plus Sign (for direction)

SURETEST DISPLAY

A 240 x 64 Full-featured Graphic LCD is used to provide versatile and clear displays of system menus as well as measurements. Characters and symbols are displayed in different fonts:

- Maximum transducer range in the selected UNITS of measure.
- Statistical mean of all measurements in memory.
- The number of the present data memory location.

Front Panel Membrane Cursor and Function Keys

The *SURETEST* is supported by a powerful Graphic User Interface (GUI). Set up, Command, or Control is done by selecting the appropriate Action Item on one of the provided Menus. Front Panel Membrane Cursor and Functions keys are defined to guide the User in selecting an Action Item.

There are 6 function (soft) keys: **F1** through **F6**. Their respective uses are clearly indicated on the LCD.

To select an Action Item, the User simply presses a Function Key (F1-F6) to get to a Menu, uses a Cursor Key to move to the Item, then hits 'ENTER'.

In addition to the 'ENTER' key, there are 4 Cursor Keys : **UP** , **DOWN** , **LEFT** , **RIGHT** .

The GUI also provides Prompts to further assist the user in navigating the Menus.

Power Up Sequence

Upon power up, the *SURETEST* automatically performs Self-tests and displays the results. Any detected non-functional hardware will be reported on the LCD. If a **4-in-1** transducer is connected, the *SURETEST* performs ZEROTARE, then displays the following default menu while continuously checking for any activity from an input transducer :

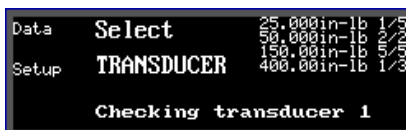

The user can either press F1 to display previously collected data (if any) or enter Setup Mode. Any detected torque measurement will cause the *SURETEST* to enter Measurements mode where the following menu is displayed:



The *SURETEST* always returns to the default menu from the measurements mode in the event there is no selection / input by the User. This serves as a reminder for more (input) measurements.

Setup Mode

The following Selections are available:

1. SELECT MODE
2. SELECT UNIT
3. SELECT LANGUAGE
4. MANUFACTURER'S DEFAULTS
5. AUTO SETTINGS
6. EDIT LIMITS
7. CLOCK ADJUST
8. CALIBRATION
9. EDIT PARAMETERS
10. CDI INTERNAL
11. ABOUT

1. Select Mode



Selects either TRACK, PEAK HOLD, FIRST PEAK, or POWER mode.



- TRACK : In this mode, the *SURETEST* continually makes Torque Measurements.
- PEAK : The *SURETEST* makes Torque Measurement at the Highest Peak.
- 1. PEAK : The *SURETEST* makes Torque Measurement at the First Peak.
- POWER : The *SURETEST* makes Torque Measurement at the Highest Peak at a faster rate.

2. Select Unit



Selects the following Torque **units** on LCD display:
Nm, dNm, cNm, mkg, ft-lb, in-lb, in-oz .

3. Select Language



Selects either English, German (Deutsch), French (Français), Spanish (Español), or Portuguese (Portugues).

4. Manufacturer's Defaults:



A warning message is first displayed. Upon confirmation by the User, the Default Settings will be loaded into the SURETEST.

5. Auto Settings



Sets up CLEAR, STORE, and SEND functions. There are 2 options: Automatic or Manual.



Selection: Automatic Clear, Automatic Store and Automatic Send data out (to RS-232 port).



Selection: Delay 9 seconds then clear the Display, Manual Store and Manual Send.



Selection: Automatic Clear, Automatic Store and Manual Send.

6. Edit Limits



Sets up high torque limit preset. (->) to go Down 1 line.
 Sets up low torque limit preset. (<-) to go Up 1 line.
 Use Up or Down cursor key to increment or decrement the respective value.
 Use Left or Right cursor key to select digit.
 Press 'Save' to activate the change. Press 'Clear' to Clear All Limit set-up.
 Press 'Escape' to Exit. Last setup is retained.



7. Clock Adjust



Edits DATE/TIME programming function.
To adjust the Clock, use LEFT or RIGHT cursor key to get to Day, Month, Year, Hour, Minute, or Second field. Then use UP or DOWN cursor key to increment or decrement the respective value.
Press and hold the cursor key to change the value quickly.

Press 'ENTER' to activate the change.



8. Calibration

This enables the User to perform calibration of the *SURETEST*. The procedures for both the single and 4-in-1 transducers are in Chapter 5.



9. EDIT PARAMETERS



Sets up serial protocol function.

Sets delay (in ms) per character upon printing.

Sets delay (in ms) per Linefeed.

Minimum block-out with zero at 0.1% F.S. in Tracking Mode.

Minimum block-out with zero at 1.0% F.S. in Peak-Hold Mode.

10. CDI INTERNAL

For Manufacturer's use only.

11. About



This provides relevant information regarding the CDI company, the software version, and the serial number of the *SURETEST* device.



12. Other Features:

Provides manual ZERO TARE.

Stores present measurement to memory.

Recalls memory data to display.

Sends all memory data, statistical analysis and histogram to printer port.

Sends data list with or without date-time stamp to computer / printer.

Manually clears display in PEAK, FIRST PEAK, POWER TOOL modes.

Sets up memory clear options in RECALL mode.

Rear Panel (Input/Output)

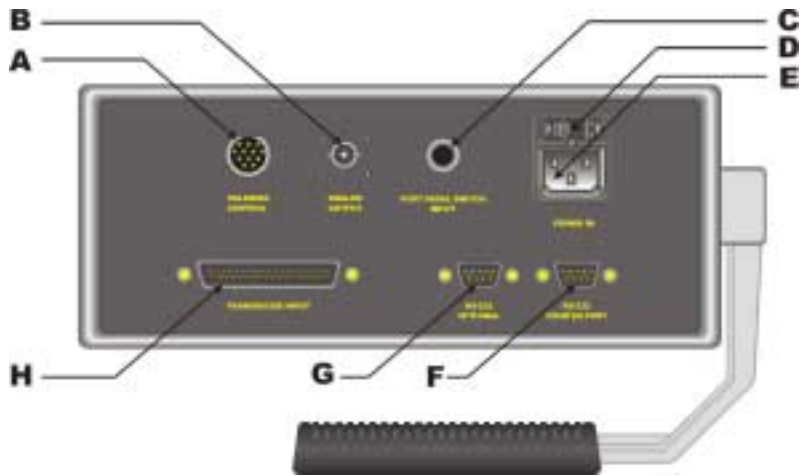

Figure 2-5: *SURETEST* Rear Panel

A- SOLENOID CONTROL (Hirose RM15TRD-12S)

PIN	FUNCTION
10	Loader Relay Common
11	Loader Relay CCW Limit
12	Loader Relay CW Limit

B ANALOG OUTPUT (BNC)

Analog output provides a voltage level output that is directly proportional to transducer input, from -1.8V (full scale counter clockwise) to +1.8V (full scale clockwise). Zero offset +/-100 mV. Linearity +/-1% of reading. Maximum load = 5 mA.

When using the 4-in-1 transducer, zero output fluctuates until one of the transducers is scan selected by applying 5% of full scale torque.

C- Foot Pedal Switch Input

D- Fuse Holder

Use AC fuse at specified rating only. (3.15 Amp).

E- INPUT AC VOLTAGE

Automatic Selection of any AC voltage from 100VAC to 230VAC, 50-60 Hz.

F- PRINTER PORT (DB-9P)

PIN	FUNCTION
2	Receive
3	Transmit
5	Ground

G- OPTIONAL (DB-9P)

PIN	FUNCTION
2	Receive
3	Transmit
5	Ground

H- TRANSDUCER INPUT (DB-37S)

PIN	FUNCTION
1	not used
2	ground
3	smart chip - bit 2
4	smart chip - bit 0
5	single xducer (-) signal
6	single xducer (+) signal
7	ground
8	4-in-1 xducer (-) signal 2
9	4-in-1 xducer (+) signal 2
10	ground
11	4-in-1 xducer (-) signal 4
12	4-in-1 xducer (+) signal 4
13	4-in-1 xducer LED 2
14	4-in-1 xducer LED 4
15	loader relay CW limit
16	not used
17	not used
18	ground
19	bridge excitation (+3V)
20	not used
21	smart chip - bit 3
22	smart chip - bit 1
23	ground
24	ground
25	4-in-1 xducer (-) signal 1
26	4-in-1 xducer (+) signal 1
27	ground
28	4-in-1 xducer (-) signal 3
29	4-in-1 xducer (+) signal 3
30	no transducer
31	4-in-1 xducer LED 1
32	4-in-1 xducer LED 3
33	loader relay CCW limit
34	loader relay common
35	Vcc (+5V@100 ma. max)
36	ground
37	bridge excitation (+3V)

***SURETEST* Transducers**

SURETEST transducers provide industry standard square drives. They feature a full bridge strain-gauge @ 350 Ohms nominal. Full range output is 1500 uE, 9mV (3mV/V @ 3.0V excitation).

Torque transducers use a built-in EEPROM memory chip that stores range identification and calibration factors. Calibration of transducers is accomplished using precision torque bars and certified weights. For additional information, refer to Chapter 5—Calibration.

After a transducer is calibrated, it provides $\pm 0.5\%$ system accuracy with any *SURETEST* System. If the transducer and *SURETEST* are calibrated together, the system accuracy increases to $\pm 0.25\%$.

Transducer Dimensions/Transducer Torque Range

Calibration also results in a specified display resolution on the *SURETEST*. Display resolution is dependent on the type of transducer being used. The following table shows display resolutions for the specified transducer with the force arm.

Display Resolution for Transducers

SURETEST torque transducers can withstand an overload of 110% of full range. The *SURETEST* alarms, (audible beep and display "OVER") at 110% of rated capacity.

To protect the tool under test or to serve as a fastener installation torque preset alert, the *SURETEST* produces a constant audible tone when the input torque exceeds the SET LOW limit. It then produces a pulsating tone when the input torque exceeds the SET HIGH limit.

The *SURETEST* Indicator ignores inputs less than 0.1% of full range in TRACK mode, 2% in PEAK HOLD mode, 7% in FIRST PEAK and POWER TOOL modes.

With the 4-in-1 transducer, the *SURETEST* System ignores inputs less than 2% of full range after scan select.

Specifications

SURETEST Torque Calibration System

System Accuracy

±0.25% of reading @ 25°C
(Suretest and transducer calibrated together)

SURETEST Transducers used with, but not calibrated to, another *SURETEST* provide a system accuracy of ±0.5% of reading @ 25°C.

Temperature Drift

+0.03%/°C (+0.017%/°F)

Display Accuracy

±0.05% of reading @ 25°C

Temperature

Operating Temperature

10 to 32°C (50 to 90°F)

Storage

-20 to 50°C (-2 to 122°F)

Humidity

Up to 90%, Non-condensing

Temperature Drift

+0.011%/°C, (+0.006%/°F)

Dimensions

Width 10.5"

Height 4.5"

Depth* 10.5"

*Includes handle, feet and connectors

Weight

8.4 lbs

Fuse:

Amperage, 3.15 amps

Data Storage/Recall w/Date Time Stamp

3,000 measurements

Statistical Analysis

Max, Min, Range, Mean, Sigma N, Sigma, Cp, Cpk
%Error, -NoGo, +NoGo, Histogram.

Printer Serial Output Port

Default: 9600 Baud Rate.

Serial Communications

RS-232 (true)
300—19.2K Baud
8 data bits
1 stop bit
no parity

Computer Serial COM Port (OPTIONAL)

Default: 19,200 Baud Rate.

RS-232 (True)

Analog Output

+(CW)/-(CCW) 1.8V at transducer full range linearity
±1% of reading

Loader Control Relays

Two, normally open, Form A, rated 12VDC @ 1/2A close contact at 110% CW or CCW of torque transducer range. For additional information refer to Transducer and System specifications.

Display Capacity

(16 bit A/D), 5 digits, ±32,000 counts

Units of Measurement

Torque
ft-lb, in-lb, in-oz, Nm, dNm, cNm, mkg, cmkg

Torque Resolution

Refer to transducer range and display resolution tables in Functional Description of this chapter.

Accuracy

±0.2% of reading @ 25°C, within specified range, when used as prescribed with the 2000-600-02 Loader.

Range and Resolution

Refer to transducer range and display resolution tables in Functional Description of this chapter.

Temperature

Operating Temperature
10 to 32°C (50 to 90°F)
Storage
-20 to 50°C (-2 to 122°F)
Humidity
Up to 90% non-condensing
Temperature Drift
+0.02%/°C (+.011%/°F)

Manual Loader Specifications

Input Torque (Hand Crank)

8 ft lb maximum (without Motorized control).

Output Torque

2000 ft-lb \pm 20 degrees rotation maximum

Power Requirements (safety solenoids)

switching From 100 to 230VAC \pm 10%, @ 50-60 Hz.

Weight (including 2000-100-02 Roll Cab)

1500 lbs.

Optional Calibration Fixturing (Load bars and Weights)

\pm 0.05% accuracy.

SETUP AND PROGRAMMING

SURETEST TORQUE CALIBRATION SYSTEM SETUP

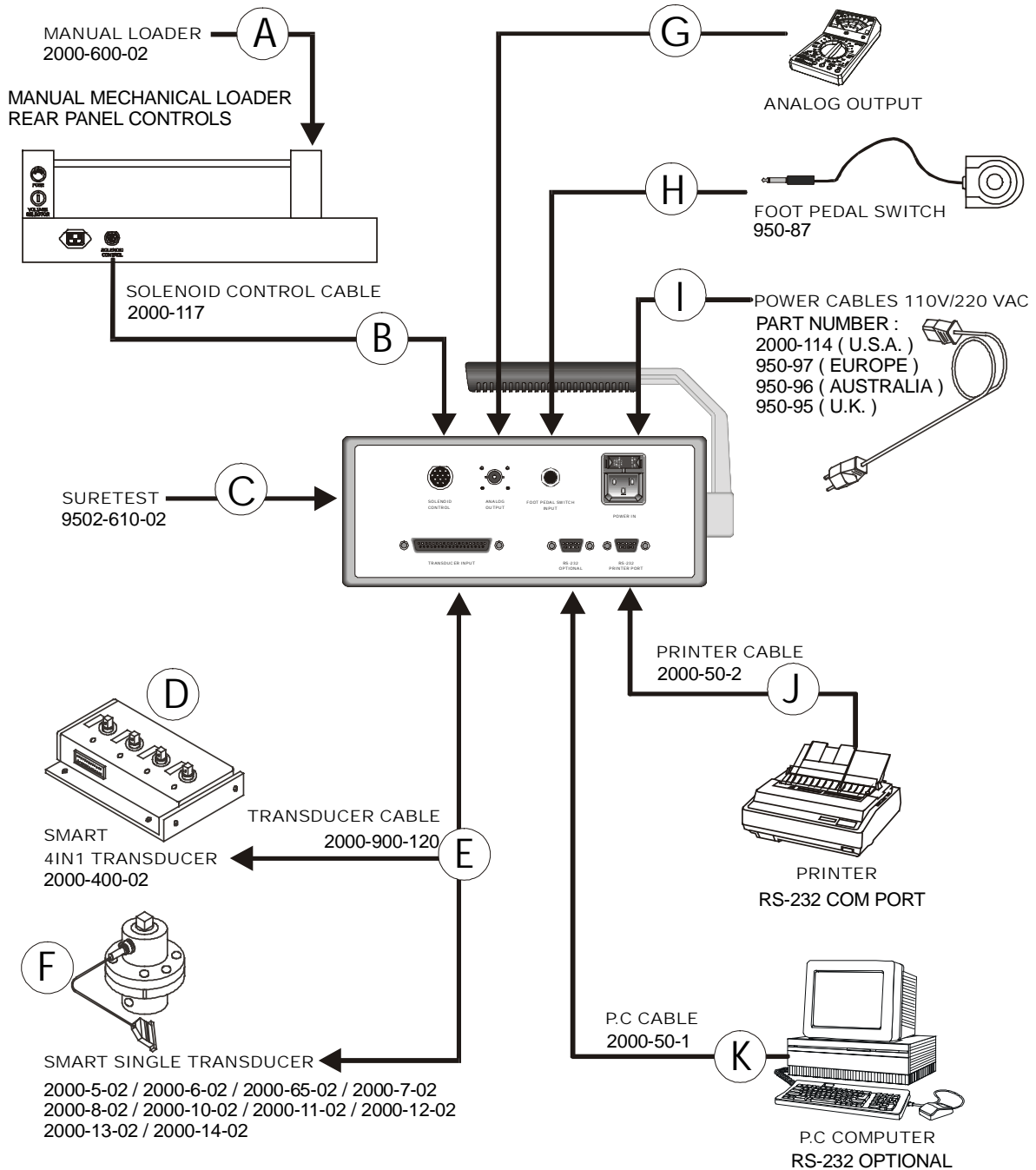

Figure 3-1: SURETEST Torque Tester/Calibrator/Loader Setup

Back panel connections

A	Manual Loader
B	Solenoid control cable
C	Suretest
D	Smart 4-in-1 transducer
E	Transducer cable
F	Smart single transducer
G	Analog Output
H	Foot cable switch
I	Power cables (110/220 VAC)
J	Printer cable
K	Personal computer cable

Note: Cable (K) can be connected to Printer Port too.

Setting Up the *SURETEST* Torque Calibration System

1. Position the roll cabinet on a level floor and lock the wheels.
2. Mount the indicator stand, part number **2000-111-0**, to the Loader.
3. Mount the *SURETEST* base unit to the stand.
4. Connect the solenoid control cable between the *Suretest* and Loader.
5. Install the appropriate *SURETEST* transducer to the Loader drive.
6. Install two (2) quick release pins, part number **2000-195-12**
7. Connect the transducer cable, part number **2000-900-120**, between the Indicator and transducer.
8. Select the appropriate AC voltage input at the rear of the Loader. Connect the AC power cables to the Loader. For additional information refer to Chapter 6—Loader Rear Panel Controls.
9. Install the safety shield to the front of the Loader.
10. Install the reaction pins into the reaction slide on the Loader.
11. Install two Linear ball bearing, part number **2000-173-11**.

For testing procedures refer to Chapter 4—Using the Torque Tester.

SURETEST Base Unit Controls

Refer to the illustration below when performing the power-up and programming procedures.



Figure 3-2: *SURETEST* Controls

- *SURETEST* Graphic LCD Display
- Power Switch
- Front Panel Membrane Function Keys

Powering the Equipment

To power the equipment, press the power button on the front of the *SURETEST*.

- At POWER ON, the *SURETEST* performs self-test and momentarily displays the results on the display.



- With no transducer installed, the display then reads:



- When applying power with the transducer connected, or when connecting a transducer while the power is on, the display momentarily reads:



ZEROTARE prompt

4-in-1 Transducer Installation

When a 4-in-1 transducer is installed, the following is displayed:

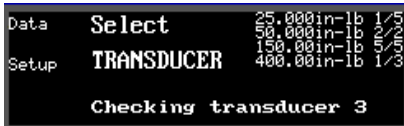

All four transducers are scanned as indicated by their associated red LED indicators. To select one of the transducers, apply at least 5% of its full range torque. To return to the scan mode, press ENTER.

Single Transducer Installation:

When a single transducer is installed, the following is displayed:



The user can enter Setup mode then proceed to make Torque measurements.

Programming Setup

Setting up Date and Time

1. Press (Setup).



2. Scroll down to select **Clock Adjust**. Press 'Enter'.
The display reads:



3. Use Left or Right Cursor to select the date/time element to be changed.
4. Increment or decrement the date/time element by repeatedly pushing Up or Down Cursor. Push and hold Up or Down Cursor to change the display quickly.
5. Press ENTER to update date and time and to return to measurements mode.

Setting Up High and Low Limits Alert

Use SET HIGH and SET LOW to protect the tool under test or serve as a fastener installation torque preset alert. The *SURETEST* produces a constant audible tone when the input torque/force exceeds the SET LOW limit. It then produces a pulsating tone when the input torque/force exceeds the SET HIGH limit.

It is important to program these limits if statistical analysis is to draw a histogram which includes reporting out-of-limit parameters.

Changing transducers does not automatically change SET HIGH and SET LOW limits.

Setting High or Low Torque Limits

1. Press (Setup).
2. Scroll down to select Edit limits.

The display reads:



3. Press 'Enter'. The display reads:
4. Press -> or <- to select Hi or Lo limit.

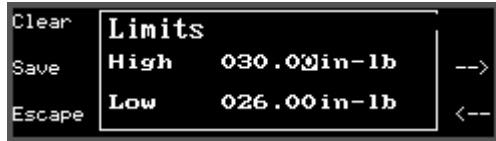

5. Use Left or Right Cursor to select a digit to be changed.
6. Increment or decrement the selected digit by pushing Up or Down Cursor. Push and hold Up or Down Cursor to change the display quickly.
7. Select and change the next digit using left and right DIGIT and up and down Cursor. Continue until all digits are set.
8. Press (Save) to save and to return to measurements mode.



Set-up AUTO CLEAR

Use **AUTO CLEAR** to program the **CLEAR**, **STORE** and **SEND** functions for automatic or manual operation. Use these functions in **PEAK HOLD**, **POWER TOOL** and **FIRST PEAK** modes to **STORE** torque measurements to memory, **CLEAR** the display, and **SEND** the last measurement captured on the display to the printer or PC. **Auto STORE** and **SEND** are initiated at either **AUTO** or delayed **CLEAR** operations.

Use the manual modes to:

- Store the present reading by pushing **STORE DATA**,
- Clear a captured display by pushing **MANUAL CLEAR**, or
- Send a measurement to the printer/port by pushing **SEND/AUTO SEND**.

Use the automatic modes to:

- Store the last measurement, and/or
- Send the last measurement to the printer/port by initiating the auto or delayed **CLEAR** function.

AUTO CLEAR can be programmed with a 1 to 9 second delay. Use this feature to visually note the reading before the display clears. **AUTO CLEAR** with no delay stores, prints and/or clears with no delay at the initiation of the next torque input

STORE DATA must be pressed to save the last reading. **AUTO CLEAR** must be selected to use **AUTO STORE** and **AUTO SEND**.

To use the AUTO CLEAR, STORE, or SEND:

1. Press **(Setup)**.
2. Scroll down to select **Auto settings**.

The display reads:



3. Press **'Enter'**. The display reads:



4. Use Right and Left Cursor to position the reverse-video (*) character under the function being changed. To program:

CLEAR, press Up or Down Cursor to select "**man**" (manual clear), "auto" (automatic), or (delayed automatic) from "**1Sec**" to "**9Sec**" seconds.

STORE, press Up or Down Cursor to select "**man**" (manual) or "**auto**" (automatic).

SEND, press Up or Down Cursor to select "**man**" (manual) or "**auto**" (automatic).

5. Press **ENTER** save **'Auto settings'** and to return to measurements mode.

DATA LIST Memory

When changing sensors, or when creating a new statistical data list, the data list memory must be cleared. The entire memory list or any single memory location may be selectively cleared. Clearing from the top of the list decrements the total number of memory locations. Clearing from inside the list shifts all subsequently taken readings down from that location and decrements the total number of memory locations.



Clear Single Memory Location

Use the procedure in this section to clear the a single memory location.

1. Press **(Data)** to enter data list display. The display reads:
2. Use the Up or Down Cursor to move to the current data. The units and present memory location are given on the top line. The total number of memory locations is to the right -- separated by a forward slash (/). The bar graph to the right of the data list indicates how far in the list the current data display is positioned.

+04.456 in-lb, Time: 23:19 Date: Feb 10, 1999



3. Press **(DEL 1)** to delete one data entry. The display automatically updates (decrements by one) the total memory locations on the top line.

Clear All Memory Locations

Use the same above procedure for single memory location. Press **(Clear)** to clear all memory locations. The following warning appears:



Select "Yes" to clear all memory.

An audible alarm sounds momentarily. The *SURETEST* automatically returns to measurements mode.

Setting Up Printer/PC Ports

The *SURETEST* is equipped with two RS-232 serial communications ports for use with an external printer or personal computer. The transfer rate is programmable from 300 to 19.2K baud rate with 8 data bits, 1 stop bit and no parity. The recommended default is 19200 baud for Optional Port and 9600 for Serial Printer.

Communication setup as: (300 – 19200); 8 Data bits; 1 Stop Bit; No Parity

Connect the Printer port to a computer or printer. All (serial) communications will take place under User's command(s) Edit Parameters set-up mode.

CHAPTER 4***SURETEST* TORQUE CALIBRATION
SYSTEM SETUP**

This chapter contains information on how to test, measure, and use the *SURETEST* Torque Calibration System.

Testing Torque Wrenches and Drivers

To use the *SURETEST* Torque Calibration System for torque wrench testing, a transducer of the appropriate range is fitted to the **2000-600-02** Manual Loader. The Loader provides a stop that holds the torque wrench handle fixed and rotates the transducer under the wrench drive. The system applies a precise, monitored torque to the wrench. For additional information refer to Chapter 6—**2000-600-02** Manual Loader.

Selecting a Transducer

When selecting a transducer, choose a single transducer that covers the low to high end capacity of the torque wrench. Although possible, it is best not to change transducers between calibration check points. For example: to test or calibrate a 20 to 100 ft lb wrench, use the **2000-10-02** transducer, which covers the range between 10 and 125 ft lb.

Installing a Transducer

Install the transducer by lining up the red mark with the “**TORQUE**” label on the loader. For additional information refer to **2000-600-02** Loader.

- Before changing or replacing transducers, adjust **SET HIGH** and **SET LOW** limits to remain within the capacity of the tool under test. For additional information refer to *Chapter 3* Setting Up High and Low Limits Alert .
- If you must retain the statistical analysis, do not change **SET HIGH** and **SET LOW** limits after changing the transducers and be careful not to exceed the wrench capacity.

The procedures provided are general. You may use or establish your own testing procedures, techniques or standards.

Dial and Bending Beam Torque Wrenches and Screwdrivers

Be sure the *SURETEST* transducer is capable of handling the intended torque to avoid damaging the transducer.

WARNING

Do not use this equipment with the power off. Always turn on the Base Unit so the torque values are indicated on the display.

1. To program the **SURETEST** Base Unit refer to Chapter 3 **Set Up and Programming**. Use **SET HIGH** and **SET LOW** limit alert, data **STORE**, display **CLEAR**, printer **SEND** and **STAT**istical analysis features.
2. Press Setup then **Select Unit** to select the desired engineering unit of measure on the display. It is easiest to match that of the tool under test.
3. Press Setup then Select **Mode** to select **TRACK** mode.
4. Install the tool onto the torque transducer-loader. Slowly apply clockwise (CW) torque using the Loader crank handle until the indicator displays the full scale torque for the tool.
Release the torque and repeat twice again to exercise the tool and the transducer.
When applying torque by hand, make sure to hold the drive end of the tool perfectly in line with the transducer drive to minimize side loading errors.
5. Remove the tool from the transducer-loader and press **Zerotare**.
6. Press **Setup** then **Select Mode** to select **PEAK HOLD** mode.
7. Reinstall the tool and apply CW torque to the first check point or calibration point recommended by the manufacturer. If the point is not specified, use the desired working torque or about 70% of full scale.
8. Read the tool display. The percentage difference between the *Suretest* and tool readings should not be greater than the sum of their respective accuracies.

Example:

When tool accuracy is 4% and *SURETEST* System accuracy is 0.25%, readings should be within $\pm 4.25\%$.

9. Release the torque, **CLEAR** the display, and reapply torque for each of the remaining check points recommended by the tool manufacturer. If no recommendation is available, check at 20%, 40%, 60%, 80% and 100% of the tool's full scale.
10. Repeat steps 4 through 9 in the counter clockwise (CCW) direction.

Adjustable or Preset “Click” Wrenches and Screwdrivers

Be sure the **SURETEST** transducer is capable of handling the intended torque to avoid damaging the transducer. Always operate the system with the power on.

WARNING

Do not use this equipment with the power off. Always turn on the Base Unit so the torque values are indicated on the display.

1. To program the **SURETEST** Base Unit refer to Chapter 3–Set Up and Programming. Use **SET HIGH** and **SET LOW** limit alert, data STORE, display CLEAR, printer SEND and STATistical analysis features.
2. Press Select Unit to select the desired engineering unit of measure as displayed on the display. It is easiest to match that of the tool under test.
3. Press **Setup Select Mode** to select **TRACK** mode.
4. Adjust the tool for maximum “click” setting. Install the tool on the torque transducer-loader. Slowly apply torque using the loader crank handle until the tool clicks or the **Suretest** displays 100% of the full scale capacity for the tool. Release the torque and repeat twice again to exercise the tool and the transducer.

When applying torque by hand, make sure to hold the drive end of the tool perfectly in line with the transducer drive to minimize side loading errors.

5. Remove the tool from the transducer-loader and press **Zerotare**.
6. Press **Setup** then **MODE** to select **FIRST PEAK** mode.

When testing “click” screwdrivers, it may be easier to use the **PEAK HOLD** mode on the **SURETEST** to capture the maximum applied torque reading.

7. If featured, adjust the micrometer or preset knob on the tool to the first check point recommended by the manufacturer, or the desired working torque, or approximately 70% of its full scale torque.
8. Reinstall the tool and apply torque until the wrench “clicks.”
9. Release the torque and note the **FIRST PEAK** or **PEAK HOLD** reading. The percentage difference between the **Suretest** reading and tool setting should not be greater than the sum of their respective accuracies.

Example:

When the tool accuracy is 4%, and the **SURETEST** accuracy is 0.25%, then readings should be within $\pm 4.25\%$.)

10. CLEAR the display and reapply torque for each of the remaining check points recommended by the tool manufacture. If no recommendation is available, test at minimum torque, 60% and 100% of full scale.
11. Repeat steps 4 through 10 in the opposite direction, if required.

Testing Power Tools

The dynamic torque characteristic of a power tool and the static torque applied when using a wrench usually result in different torque readings. Spinning electric and pneumatic motor armatures contain inertia that produces a higher torque reading than what is actually absorbed by a practical fastener. The difference is also due to individual fastener installation characteristics that exhibit anywhere from a gradually increasing run-down torque, (soft-joint) to a free speed, sudden dead stop, (hard-joint). The way in which a particular operator responds to the tool's reaction forces can also be reflected in the resulting torque measurements.

A joint rate simulator is required when testing a power tool to allow start-up rotation of the tool's armature. The simulator is experimentally adjusted to replicate the average joint hardness of the intended work. Joint rate simulators that may be used with transducers ranging from 50 in lb to 1000 in lb are:

- 50 in lb max, 1/4" internal square drive for use on **2000-6-02** transducer, part number **900-1-0**.
- 400 in lb max, for use on **2000-7-02** transducer, part number **900-2-0**, or
- 1000 in lb max, for use on **2000-8-02** transducer, part number **900-3-0**.

Be sure to operate any pneumatic or electrical power tool according to the manufacturer's recommendations.

Non-Impact Tools

Be sure the **SURETEST** transducer is capable of handling the intended torque to avoid damaging the transducer. Always operate the system with the power on.

WARNING

Do not use this equipment with the power off. Always turn on the Base Unit so the torque values are indicated on the display.

1. To program the **SURETEST** Base Unit, refer to Chapter 3—Set Up and Programming in this manual. Use **SET HIGH** and **SET LOW** limit alert, data **STORE**, display **CLEAR**, printer **SEND** and **STAT**istical analysis features.
2. Press Setup then select **UNIT** to select the desired engineering unit of measure as displayed on the LCD display. It is easiest to match that of the tool under test.
3. Press Setup then **MODE** to select **TRACK** mode.
4. Adjust the power tool to the desired torque output, if possible.
5. Adjust the appropriate joint rate simulator assembly for the desired soft-hard configuration.
6. Install the joint rate simulator onto the **SURETEST** transducer, as shown in Figure 4-1. Secure the transducer set screw, if provided. Loosen the simulator load screw using the appropriate hex or box wrench.

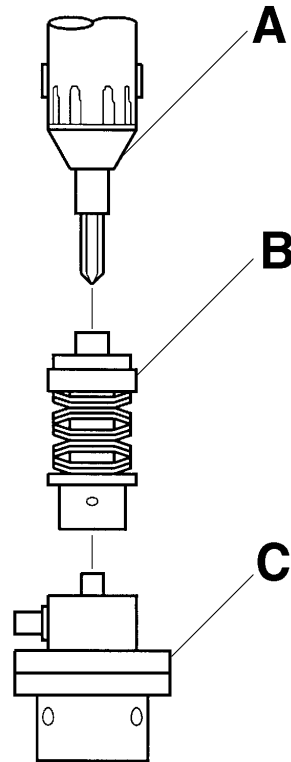

Figure 4-1: Power Tool Test Setup

- A – Power Tool
- B – Joint Rate Simulator
- C – Transducer

7. Couple the power tool to the joint rate simulator using the appropriate accessory adaptors and bit.
8. While holding the power tool drive perfectly in-line with the transducer drive, energize the tool until its motor stalls or, if featured, the tool clutch slips.
9. Remove the power tool. Loosen the joint rate simulator load screw.
10. Repeat steps 7 through 9 twice again to exercise the tool-simulator assembly and the *SURETEST* transducer.
11. Remove the power tool from the loader-transducer and press **Zerotare**.
12. Press Select Mode to select POWER (TOOL) mode.

13. While holding the power tool drive perfectly in-line with the transducer drive, reinstall the tool onto the simulator and energize the tool until its motor stalls or, if featured, the tool clutch slips. Be careful not to add torque by turning the tool by hand.
14. Release the torque and note the Power tool reading on the display.
15. CLEAR the display.
16. Repeat steps 4 through 15 in the opposite direction, if required.

Given the variables typical of power tools and fastener joint dynamics, a number of readings should be taken and averaged to best determine the accuracy and repeatability for each tool.

Displaying Statistical Analysis

The *SURETEST* Base Unit accumulates torque measurements in a data list. The list is created with each AUTO or MANUAL data store entry. Statistical analysis is calculated on the list, and if SET HIGH and SET LOW limits are established, draws a simple histogram of the results. These features are very useful in statistical process control (SPC) management. Statistical analysis can be previewed on the display or sent directly to a printer/computer port. For additional information on setting up printer or PC ports, refer to Chapter 3—Set Up and Programming in this manual.

Displaying Statistical Analysis

1. Press **Data** . Then **Format** .

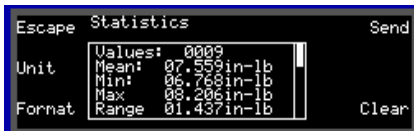

Figure 4-2: Statistical Analysis Display

2. Repeatedly press **Up** or **Down** Cursor Key to scroll through the LCD display as shown:

```

Value: 0009
Mean: 07.559 in-lb
Min: 06.768 in-lb
Max: 08.206 in-lb
Range: 01.437 in-lb
SigmaN 00.526 in-lb
Sigma 00.558 in-lb
Cp: 0.3287
Cpk 0.2636
%Err 33.333%
-NoGo 1
+NoGo 2

```

3. Press **Escape** to return to measurements mode.

Printing Statistical Analysis

1. Press **Data** , then Press **Format**.

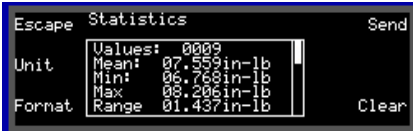

2. Press **SEND** to display the Print out menu.



Use **Down** key to select **Send Statistics** then press Enter to Print.

3. Press **Escape** to return to measurements mode.

SPC PRINT-OUT

SPC listing

PART NO.

NAME

STATISTICAL ANALYSIS

Time : 16/Nov/1998 14:23

** LIMIT DATA **

Set High: 254.85 in-lb

Set Low : 251.55 in-lb

```

0001 254.45 in-lb
0002 253.91 in-lb
H0003 254.89 in-lb
0004 252.89 in-lb
0005 253.42 in-lb
0006 253.31 in-lb
0007 252.40 in-lb
0008 252.49 in-lb
0009 252.61 in-lb
L0010 251.49 in-lb
    
```



```
  ** R E S U L T **
Data   : 0010
Max    : 254.89 in-lb
Min    : 251.49 in-lb
Range  : 3.4039 in-lb
Mean   : 253.19 in-lb
Sig.n  : 0.9755 in-lb
Sigma  : 1.0283 in-lb
Cp     : 0.5348
Cpk    : 0.5317

%Err.  : 20.000%
-NoGo  : 0001
+NoGo  : 0001
  H I S T O G R A M
LSL    :251.55 in-lb
USL    :254.85 in-lb
DIV    :    10

-NG0001:X
LSL    -----
A 0000:
B 0000:
C 0002:XX
D 0001:X
E 0001:X
F 0002:XX
G 0000:
H 0001:X
I 0001:X
J 0000:
USL    -----
+NG0001:X
Scale: X =01
A    251.55 in-lb<
B    251.88 in-lb<
C    252.20 in-lb<
D    252.53 in-lb<
E    252.86 in-lb<
F    253.20 in-lb<
G    253.53 in-lb<
H    253.85 in-lb<
I    254.19 in-lb<
J    254.51 in-lb<
      254.85 in-lb
```

Figure 4-4: Sample Statistical Data Printout

Displaying or Downloading Data List

Torque measurements stored in the data list also include a date and time stamp. For additional information on setting up printer or PC ports, refer to Chapter 3—Set Up and Programming in this manual.

Displaying Data List

1. Press DATA.

The display reads:



2. Torque Units of measure are displayed at top of the display with present memory location/total memory locations to the right. Torque readings are to the left of the Time and Date.

The selected reading is highlighted.

3. Use **Up** and **Down** key to view the data list.
4. Press **Escape** to return to measurements mode.

Downloading Data List to Printer

1. Press **DATA** .
2. Press **SEND** .

The display reads:



Figure 4-5: Data Download Display.

3. To download the raw data list, Select Send raw data then Press Enter.
4. To download the data list plus date-time stamp, press Down. To select Send Data, Time/Date Then press Enter to print.
5. Press Escape to return to measurements mode.

How to Use Analog Output (Rear Panel BNC Connector)

Analog Output on the *SURETEST* provides a real time voltage level that is directly proportional to the torque applied to the transducer. It is useful for direct driving equipment such as analog plotters and chart recorders, or interfacing to a computer/controller with analog to digital (A/D) data acquisition capability. Maximum output loading must be less than 5 mA.

The output varies between approximately +1.8 volts, full clockwise (CW) torque applied and approximately -1.8 volts, full counter clockwise (CCW) torque applied. Zero offset is within ± 100 mv. Linearity is better than $\pm 1\%$ of reading.

When used with the 4-in-1 transducer, zero output varies with the scan of the four transducers. Select one of the four by applying at least 5% of its full range torque to it. Press ENTER to return to scanning.

1. To program the *SURETEST* Base Unit, refer to Chapter 3—Set Up and Programming. Use SET HIGH and SET LOW limit alert, data STORE, display CLEAR, printer SEND and STATistical analysis features.
2. Press Select Mode to select the TRACK mode.
3. Connect the recording or monitoring equipment to the ANALOG OUTPUT port using a BNC coaxial connector.
4. With no torque applied, measure the ANALOG OUTPUT voltage and adjust or program your equipment for zero.
5. Apply full range torque to the transducer in the CW direction.
6. Measure the ANALOG OUTPUT voltage and adjust or program your equipment to display the full range torque value.
7. Apply full range torque to the transducer in the CCW direction.
8. Measure the ANALOG OUTPUT voltage and adjust or program your equipment to display the full range torque value.

CHAPTER 5

Calibration

The *SURETEST* Torque Calibration System is factory calibrated using precision torque test arms, certified weights and laboratory grade equipment. *SURETEST* series transducers must be positioned horizontally, with torque applied within ± 15 degrees of horizontal.

This chapter contains calibration instructions and information for the *SURETEST* system.

Annual calibration is recommended. Calibration by the user is recorded in memory and voids factory certification. Contact your authorized CDI sales representative for calibration and repair services.

If extreme calibration precision is required, refer to Correction Factors on Test Weights in this chapter.

Mounting Details

Single Transducer Mounting Detail for Calibration

Single transducer calibration requires the use of a reaction stand and transducer calibration block.

As shown in *Figure 5.1*, the transducer is secured to the calibration block with two quick release pins.

- Both pins must be installed for safety and stability of the mount.
- The white mark on the transducer is aligned in the up position.

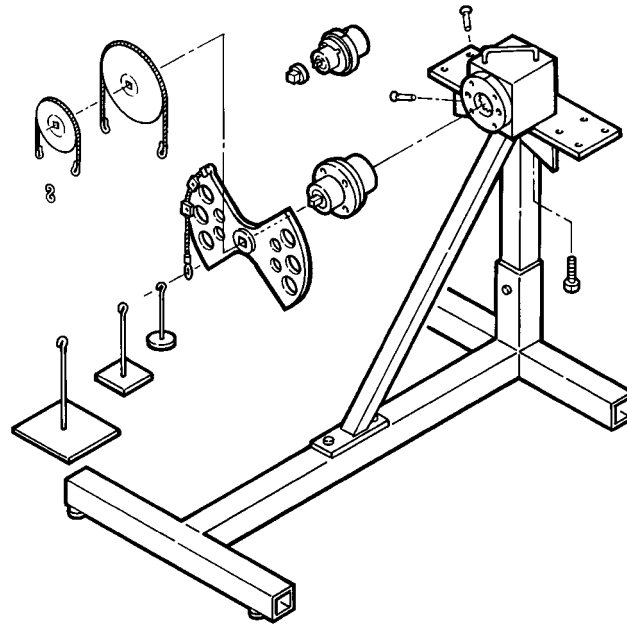

Figure 5-1: Single Low Torque Transducer Mounting Detail

Torque Under 250 ft lb

Mount the calibration block at the center of the stand with two 1/2-13 socket head cap screws with test bars that are 10" or shorter. Install these screws using the supplied torque wrench and 3/8-3/8 socket driver adapter. Use this configuration for up to 250 ft lb of applied torque. A 1/2" to 3/8" reducer is required when mounting the 10" arm to transducers having 3/8" drives.

Torque Over 250 ft lb

For torque calibration above 250 ft lb, the calibration block is moved to the left for CCW loading and to the right for CW loading. The torque arm is always extended over the front of the reaction bracket for both CW and CCW torque applications. In this configuration, useful up to 2000 ft lb, the calibration block is secured to the stand using four 1/2-13 socket head cap screws, each torqued to 75 ft lb. For additional information refer to *Figure 5-2*.

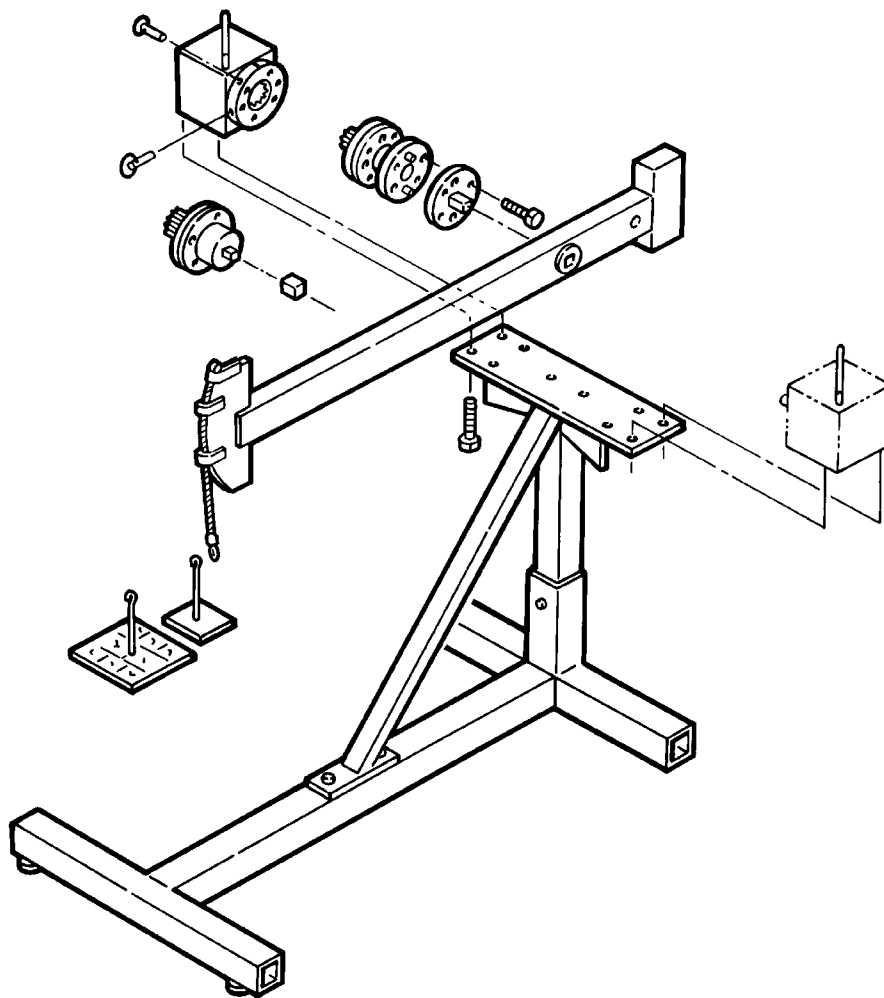

Figure 5-2: Single High Torque Transducer Mounting Detail

The 2000-12-02, 600 ft lb transducer, requires the 1-1/4" to 3/4" drive reducer, supplied, to couple to the 40" test bar.

WARNING

Always position the 40" arm over the front of the stand as shown. Never extend the test arm behind the stand because the stand will tip over when weights are applied.

The 40" test arm is coupled to the 2000-13-02, 1000 ft lb, and 2000-14-02, 2000 ft lb transducers using a 1-1/4" drive adapter plate.

1. *Remove the internal drive adapter plate and bottom plate from the transducer using the torque wrench, ratchet head and 3/8-3/8 hex bit or 3/4" open end adapter supplied.*
2. Remove separated adapter from calibration block.
3. Attach transducer to the calibration block so that red mark on transducer lines up with white dot in left bottom corner on calibration block. Tighten six 1/2"-13 hex head bolts to 75 ft lb torque.
4. Attach the 1-1/4" drive adapter plate using six 1/2"x13 hex head bolts, each torqued to 75 ft lb using the torque wrench, and 3/4" open end adapter, supplied.
5. After calibration, re-install the internal drive plate and bottom plate using appropriate 1/2"x13 screws, torquing them to 75 ft lb. Also re-install the separated adapter to the calibration block.

Appropriate hangers and weights are listed in the calibration check point table in this chapter. Notice that the weight of the hanger is included in all measurements. The hanger must be removed to set ZERO TARE on the Indicator.

4-in-1 Transducer Mounting Detail for Calibration

The 4-in-1 transducer mounts upright with integral transducers in the horizontal position. This transducer may be mounted to a

- Wall using four 1/4" bolts torqued to 10 ft lb, or
- Sturdy table using a right angle bracket. Refer to *Figure 5-3*.

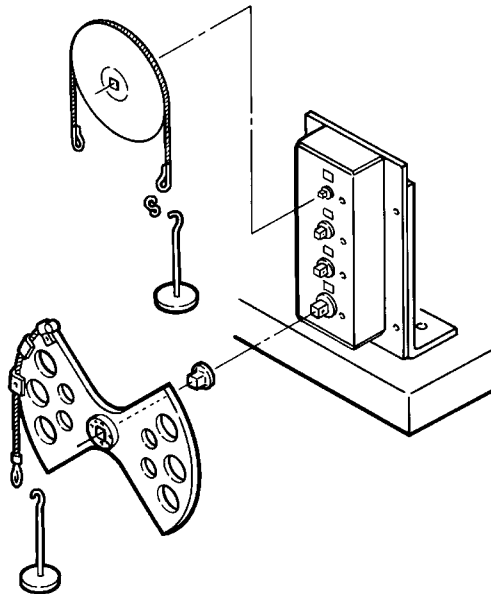

Figure 5-3: 4-in-1 Transducer Mounting Detail

The 4-in-1 transducer may also be mounted to the calibration stand, shown in *Figure 5-2*, using the standoff fixture and bracket assembly. For this mounting configuration the two slide knobs must be loosened and four 5/16-18 bolts attached to secure the 4-in-1 transducer to the bracket assembly.

Quick Check

WARNING

Always be alert to the potential for personal injury that may be caused by excessive torque applications, careless handling of heavy weights, and out-of-balance or unsafe weight distribution.

1. With the SURETEST ON, select TRACK mode, and select the UNITS of measure appropriate to the transducer as specified in the calibration check point table in this chapter.
2. Install the transducer to be checked and allow a 5 minute warm up period to stabilize the electronic circuits and transducer elements.
3. Transducers are mounted horizontally for calibration as instructed in Mounting Details in this chapter. Mount the 4-in-1 transducer to a sturdy bench using the bracket provided. Mount single transducers horizontally using the accessory stand and block. Attach the specified torque test bar, wheel or butterfly, secured with its drive retention screw, and install the specified hanger for clockwise (CW) torque application.
4. Apply and remove the full range torque for the transducer three times.
5. Remove the weights and hanger, but leave the arm attached, and press ZERO TARE.
 6. *At each of the check points specified for the transducer in the calibration check point table (in this chapter), apply torque in the CW direction and verify the display readings are within 0.25% of applied torque. If any reading is out of specification, proceed to Calibrating SURETEST Torque Transducers in this chapter.*
7. Repeat Steps 3 through 6 in the counter clockwise (CCW) direction.

When using the 2-1/2" or 5" test wheel, a small "S" hook is supplied to provide a positive zero bias in the direction (CW or CCW) that the calibration is performed. Do not remove the "S" hook when setting zero tare.

Suggested Transducer Calibration Check Points, Bars, Hangers and Weights

(Sheet 1 of 2)

Part No.	Range	Bar Length	Hanger Weight	Calibration Points	Check Points	Weights to Add (n) = more than 1	Total Weight
2000-5-02							
	15-200 in oz	2.5"	none		15.0 in oz	2 oz, 4 oz	6 oz
		2.5"	1/2 lb	1	20.0 in oz	20.0 in oz	1/2 lb
		2.5"	1/2 lb	2	40.0 in oz	40.0 in oz	1 lb
		2.5"	1/2 lb	3	80.0 in oz	80.0 in oz	2 lb
		2.5"	1/2 lb	4	120.0 in oz	120.0 in oz	3 lb
		2.5"	1/2 lb	5	200.0 in oz	200.0 in oz	5 lb
2000-6-02							
	4-50 in lb	5.0"	1/2 lb		4.0 in.lb	0.3 oz, 0.5 oz, 4 oz	0.8 lb
		5.0"	1/2 lb	1	5.0 in lb	5.0 in lb	1 lb
		5.0"	1/2 lb	2	10.0 in lb	10.0 in lb	2 lb
		5.0"	1/2 lb	3	20.0 in lb	20.0 in lb	4 lb
		5.0"	1/2 lb	4	30.0 in lb	30.0 in lb	6 lb
		5.0"	1/2 lb	5	50.0 in lb	50.0 in lb	10 lb
2000-65-02							
	15-150 in lb	5.0"	1/2 lb	1	15.0 in lb	15.0 in lb	3 lb
		5.0"	1/2 lb	2	30.0 in lb	30.0 in lb	6 lb
		5.0"	1/2 lb	3	60.0 in lb	60.0 in lb	12 lb
		5.0"	1/2 lb	4	90.0 in lb	90.0 in lb	18 lb
		5.0"	1/2 lb	5	150.0 in lb	150.0 in lb	30 lb
2000-7-02							
	30-400 in lb	10.0"	1/2 lb		30.0 in lb	1/2 lb, 2lb	3 lb
		10.0"	1/2 lb	1	40.0 in lb	40.0 in lb	4 lb
		10.0"	1/2 lb	2	80.0 in lb	80.0 in lb	8 lb
		10.0"	1/2 lb	3	160.0 in lb	160.0 in lb	16 lb
		10.0"	1/2 lb	4	240.0 in lb	240.0 in lb	24 lb
		10.0"	1/2 lb	5	400.0 in lb	400.0 in lb	40 lb
2000-8-02							
	80-1000 in lb	10.0"	7-1/2 lb		80.0 in lb	1/2 lb	8 lb
		10.0"	7-1/2 lb	1	100.0 in lb	100.0 in lb	10 lb
		10.0"	7-1/2 lb	2	200.0 in lb	200.0 in lb	20 lb
		10.0"	7-1/2 lb	3	400.0 in lb	400.0 in lb	40 lb
		10.0"	7-1/2 lb	4	600.0 in lb	600.0 in lb	60 lb
		10.0"	7-1/2 lb	5	1000 in lb	1000 in lb	100 lb
2000-10-02							
	10-125 ft lb	10.0"	7-1/2 lb		10 ft lb	1/2 lb, (2) 2 lb	12 lb
		10.0"	15 lb	1	12.5 ft lb	12.5 ft lb	15 lb
		10.0"	15 lb	2	25.0 ft lb	25.0 ft lb	30 lb
		10.0"	15 lb	3	50.0 ft lb	50.0 ft lb	60 lb
		10.0"	15 lb	4	75.0 ft lb	75.0 ft lb	90 lb
		10.0"	15 lb	5	125.0 ft lb	125.0 ft lb	150 lb
2000-11-02							
	20-250 ft lb	10.0"	15 lb		20.0 ft lb	(2) 2 lb, 5 lb	24 lb
		10.0"	15 lb	1	25.0 ft lb	25.0 ft lb	30 lb
		10.0"	15 lb	2	50.0 ft. lb	50.0 ft. lb	60 lb
		10.0"	15 lb	3	100.0 ft. lb	100.0 ft. lb	120 lb
		10.0"	15 lb	4	150.0 ft. lb	150.0 ft. lb	180 lb
		10.0"	15 lb	5	250.0 ft. lb	250.0 ft. lb	300 lb

Suggested Transducer Calibration Check Points, Bars, Hangers and Weights

(Sheet 2 of 2)

Part No.	Range	Bar Length	Hanger Weight	Calibration Points	Check Points	Weights to Add (n) = more than 1	Total Weight	
2000-12-02								
60-600 ft lb		40"	15 lb	1	60.0 ft lb	60.0 ft lb	1 lb, 2 lb	18 lb
		40"	15 lb	2	120.0 ft lb	120.0 ft lb	1 lb, (2) 10 lb	36 lb
		40"	15 lb	3	240.0 ft lb	240.0 ft lb	2 lb, 5 lb, 10 lb, (2) 20 lb	72 lb
		40"	15 lb	4	360.0 ft lb	360.0 ft lb	1 lb, 2 lb, 10 lb, (4) 20 lb	108 lb
		40"	15 lb	5	600.0 ft lb	600.0 ft lb	5 lb, (3) 20 lb, (2) 50 lb	180 lb
2000-13-02								
100-1000 ft lb		40"	15 lb	1	100.0 ft lb	100.0 ft lb	5 lb, 10 lb	30 lb
		40"	15 lb	2	200.0 ft lb	200.0 ft lb	5 lb, (2) 20 lb	60 lb
		40"	15 lb	3	400.0 ft lb	400.0 ft lb	5 lb, (5) 20 lb	120 lb
		40"	15 lb	4	600.0 ft lb	600.0 ft lb	5 lb, (2) 10 lb, (2) 20, (2) 50 lb	180 lb
		40"	15 lb	5	1000.0 ft lb	1000.0 ft lb	5 lb, (4) 20 lb, (4) 50 lb	300 lb
2000-14-02								
200-2000 ft lb		40"	50 lb	1	200.0 ft lb	200.0 ft lb	(2) 5 lb	60 lb
		40"	50 lb	2	400.0 ft lb	400.0 ft lb	20 lb, 50 lb	120 lb
		40"	50 lb	3	800.0 ft lb	800.0 ft lb	(2)5 lb, (4)20 lb, (2)50 lb	240 lb
		40"	50 lb	4	1200.0 ft lb	1200.0 ft lb	(2)5 lb, (5)20 lb (4)50 lb	360 lb
		40"	50 lb	5	2000.0 ft lb	2000.0 ft lb	(2)5 lb, (4)10 lb, (5)20 lb, (8)50 lb	600 lb
2000-400-02								
4-50 in lb		5"	1/2 lb			4.0 in lb	0.3 oz, 0.5 oz, 4 oz	0.8 lb
(4-in-1)		5"	1/2 lb	1	5.0 in lb	5.0 in lb	1/2 lb	1 lb
		5"	1/2 lb	2	10.0 in lb	10.0 in lb	1/2 lb, 1 lb	2 lb
		5"	1/2 lb	3	20.0 in lb	20.0 in lb	1/2 lb, 1 lb, 2 lb	4 lb
		5"	1/2 lb	4	30.0 in lb	30.0 in lb	1/2 lb, 1 lb, (2) 2 lb	6 lb
		5"	1/2 lb	5	50.0 in lb	50.0 in lb	1/2 lb, 1 lb, (4) 2 lb	10 lb
30-400 in lb		10"	1/2 lb			30.0 in lb	1/2 lb, 2 lb	3 lb
		10"	1/2 lb	1	40.0 in lb	40.0 in lb	1/2 lb, 1 lb, 2 lb	4 lb
		10"	1/2 lb	2	80.0 in lb	80.0 in lb	1/2 lb, 1 lb, (3) 2 lb	8 lb
		10"	1/2 lb	3	160.0 in lb	160.0 in lb	1/2 lb, (3) 5 lb	16 lb
		10"	1/2 lb	4	240.0 in lb	240.0 in lb	1/2 lb, 1 lb, 2 lb, (4) 5 lb	24 lb
		10"	1/2 lb	5	400.0 in lb	400.0 in lb	1/2 lb, 1 lb (4) 2 lb, (6) 5 lb	40 lb
80-1000 in lb		10"	7-1/2 lb			80.0 in lb	1/2 lb	8 lb
		10"	7-1/2 lb	1	100.0 in lb	100.0 in lb	1/2 lb, 2 lb	10 lb
		10"	7-1/2 lb	2	200.0 in lb	200.0 in lb	1/2 lb, 2 lb, (2)5 lb	20 lb
		10"	7-1/2 lb	3	400.0 in lb	400.0 in lb	1/2 lb, 2 lb, (2)5 lb, (2)10 lb	40 lb
		10"	7-1/2 lb	4	600.0 in lb	600.0 in lb	1/2 lb, 2 lb, (2)5 lb, (4)10 lb	60 lb
		10"	7-1/2 lb	5	1000 in lb	1000 in lb	1/2 lb, 2 lb, (2)5 lb, (4)10 lb, (2)20	100 lb
20-250 ft lb		10"	15 lb			20.0 ft lb	(2) 2 lb, 5 lb	24 lb
		10"	15 lb	1	25.0 ft lb	25.0 ft lb	5 lb, 10 lb	30 lb
		10"	15 lb	2	50.0 ft. lb	50.0 ft. lb	5 lb, (2) 20 lb	60 lb
		10"	15 lb	3	100.0 ft. lb	100.0 ft. lb	5 lb, (2) 50 lb	120 lb
		10"	15 lb	4	150.0 ft. lb	150.0 ft. lb	5 lb, (3) 20 lb, (2) 50 lb	180 lb
		10"	15 lb	5	250.0 ft. lb	250.0 ft. lb	5 lb, (4) 20 lb, (4) 50 lb	300 lb

Torque Calibrations

SURETEST New Transducer Calibration

Improper calibration can result in torque measurement errors. Follow these procedures precisely. If an error is made in the procedure, turn the *Suretest* off and begin again. Users are responsible for the results of their transducer calibration.

SURETEST series Torque transducers can only be calibrated using the SURETEST Base Unit. Calibration data is calculated and then stored in the FLASH memory chip of the transducer by the microcontroller in the Indicator.

WARNING

Always be alert to the potential for personal injury and equipment damage that may be caused by excessive torque applications, careless handling of heavy weights, and out-of-balance or unsafe weight distribution.

Equipment

- Precision test arms and certified calibration weights.
- Test stand.

Procedure

1. Turn the SURETEST ON. Refer to the calibration check point table in this chapter for the transducer calibration check points, as well as the specified arms, hangers and weights.
2. Install the transducer being calibrated and allow a 5 minute warm up period to stabilize the electronic circuits and transducer elements.
3. Mount the 4-in-1 transducer upright, drives horizontal, as shown in *Figure 5-3*, or mount single transducers horizontally using the accessory stand and block as detailed in *Figure 5-2*. Attach the specified torque arm, secured with the drive retention screw, and install the specified hanger for clockwise (CW) torque application. Use the "S" hook on the 2-1/2" or 5" bars.
4. Apply and release full scale torque to the transducer three times in the CW direction, then remove the weights and hanger. Leave the torque arm installed. Press Soft Key Setup to select Setup Menu.
5. Use DOWN Cursor key to scroll down to **Calibration** Item. Press 'ENTER'.



6. Enter the following code into the display using the Cursor Keys: **5222**



(Left / Right to select digit ; Up / Down = Increment / Decrement value ; 'Enter' to accept)

Calibration CW:

7. Select Calibrate CW. Press 'ENTER'.



A warning is displayed.



Select 'Yes'. Press 'Enter'.



8. Using the Up or Down Cursor keys, enter "1" for a **single transducer**.



Using the Up or Down Cursor keys, enter "4" for the **4-in-1 transducer**.

9. Press ENTER. The display reads:

- Press F2 key and select the desired torque unit.
- Using the Up and Down Cursor keys, enter the Full Scale value for the 4-in-1 transducer to calibrate. Possible values are:
 - 1 = 50 in-lb
 - 2 = 400 in-lb
 - 3 = 1000 in-lb
 - 4 = 250 ft-lb
 (For 4 in 1 Transducers display shows : CHECKING TRANSDUCER.)
 Apply load until “ Full Scale [units] shows on display.

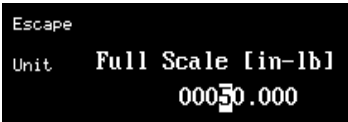

- Press ENTER. To accept 50 in.lb Transducer.

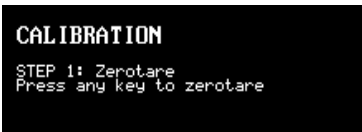

Press any key to zerotare.

- Press any key. The LCD displays:



- Apply torque using the precision arm, hanger or certified weights listed as calibration point 1 in the calibration check point table in this chapter. When the reading is stable, push and hold the Up or Down Cursor Keys to get the correct torque value reading. Repeat the procedure for points 2,3,4, and 5 of the same table.

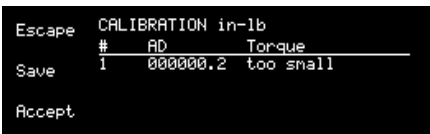

Apply 10% Torque = 5 in.lb

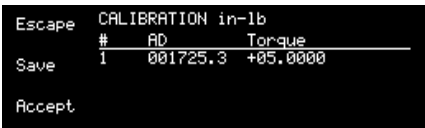

13. Press **(Accept)** to accept the calibration value (1st Cal point).
Apply 20% Torque = 10 in.lb

```
Escape CALIBRATION in-lb
# AD Torque
Save 1 001725.5 +05.0000 ✓
      003449.9 +10.0000 ✓
Accept 006912.2 +20.0000 ✓
```

14. Press **(Accept)** to accept the calibration value (2nd Cal point) .
Apply 40% Torque = 20 in.lb

```
Escape CALIBRATION in-lb
# AD Torque
Save 1 001725.5 +05.0000 ✓
      003449.9 +10.0000 ✓
Accept 006912.2 +20.0000 ✓
```

16. Press **(Accept)** to accept the calibration value (3rd Cal point) .
Apply 60% Torque = 30 in.lb

```
Escape CALIBRATION in-lb
# AD Torque
Save 1 001725.5 +05.0000 ✓
      003449.9 +10.0000 ✓
Accept 4 006912.2 +20.0000 ✓
      010390.5 +30.0000 ✓
```

17. Press **(Accept)** to accept the calibration value (4th Cal point) .
Apply 100% Torque = 50 in.lb

```
Escape CALIBRATION in-lb
# AD Torque
Save 1 001725.5 +05.0000 ✓
      003449.9 +10.0000 ✓
Accept 4 006912.2 +20.0000 ✓
      010390.5 +30.0000 ✓
      017255.7 +50.0001 ✓
```

18. Press **(Accept)** to accept the calibration value (5th Cal point) .
The display will show: Saving then show the Calibration table.

19. **Remove all weights and the arm.**
Press any key, go back to Select mode.

Calibration CCW:
(Go to step 7 then select CCW)

20. Select "Calibrate CCW" on the LCD display.

```
Escape
Passcode
View Cal Table
Calibrate CW
Calibrate CCW
Erase Xdata
Use ↑ ↓ ← → to adjust ↓ to accept
```

Apply and release full scale torque to the transducer three times in the CCW direction then remove the weights and hanger, wait for about 15 seconds.

21. Repeat steps 12 through 19, applying all torque in the counter clockwise (CCW) direction.

- 22. All readings show minus sign (-). Press F1 twice to return to measurement mode.

SURETEST Indicator Calibration

WARNING:

Improper calibration can result in torque measurement errors. Follow these procedures precisely. If an error is made in the procedure, turn the *Suretest* off and begin again. Users are responsible for the results of their calibration.

Equipment

- Laboratory grade millivolt meter for calibration measurements capable of resolving 1/100 millivolts.
- Calibration fixture as shown in *Figure 5-2*.

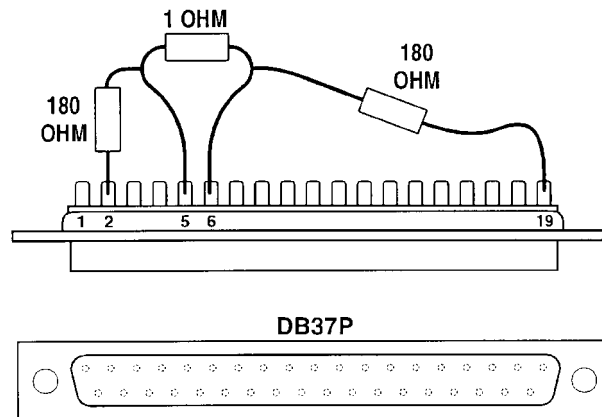

Calibration fixture *Figure 5-2*.

Procedure

1. With the power off, plug the calibration fixture into the TRANSDUCER INPUT connector at the back of the SURETEST Base Unit.
2. Turn the power on. After initialization, the LCD display reads:

No Transducer Connected

3. Press Soft Key **Setup** to get to Setup Menu.



Use DOWN Cursor key to scroll down to **Calibration** Item. Press 'ENTER'.
The display reads:

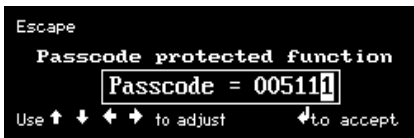

4. Enter the following code into the display using the Cursor Keys: **5111**
(Left / Right to select digit ; Up / Down = Increment / Decrement value ; 'Enter' to accept)

Calibrate tester

Using a laboratory millivolt meter, measure the voltage across pin 2 (ground) and 19 (Gage Excitation) of the calibration fixture.

The display reads:

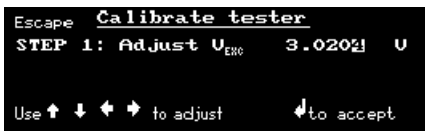

Example:

3.0211 volts

Program the measured voltage into the SURETEST Base Unit using the Cursor Keys. (Use Up, Down, Left and Right Cursor Keys to match the *Suretest* display to the millivolt-meter). Then Press 'Enter' to accept.

5. Next, the display reads:



Short pins **5 and 6 together** on the **calibration fixture**. Then hit Enter key.

6. Next, the display reads:

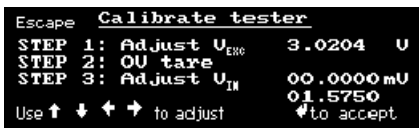

Remove the short between pins 5 and 6 of the calibration fixture.

Using a laboratory millivolt meter, measure the voltage across pins 5 and 6.

Example: 08.0622 mV

7. Program the measured voltage into the SURETEST Indicator as demonstrated in the example, “+08.0622” by pushing and holding the Up or Down Cursor keys.
8. Press ENTER. The display momentarily reads:
SAVING...
9. Turn the power to OFF. Remove the calibration fixture.

Gravitational Effects

Correction Factors on Test Weights

Weights used in torque calibration are affected by their acceleration due to:

- Altitude above or below sea level, and
- Latitude on earth between the equator and the poles.

Test bars are not affected by these conditions. The accuracy of torque wrenches and testers does not change due to changes in geographic location. Only when using weights must correction factors be considered. After an analysis is made for a given location, it is often found that the correction factor is insignificant.

Two methods of correction are provided. They are:

- Correction factor for check point readings adjusts the calibration readings without changing the applied weight.
- Correction factor for weights adjusts the weight applied without changing check point readings. For additional information refer to Gravitational Charts in this chapter.

Gravitational Charts

The charts in this section are taken from CRC Handbook of Chemistry and Physics, 58th Edition. CRC Press, Inc., 18901 Cranswood Parkway. Cleveland, Ohio 44128.

Acceleration Due to Gravity for Sea Level at Various

Latitudes

Latitude, degrees	Acceleration, cm/sec ²	Latitude, degrees	Acceleration, cm/sec ²
0	978.039	46	980.711
5	978.078	48	980.892
10	978.195	50	981.071
15	978.384	52	981.247
20	978.641	54	981.422
25	978.960	56	981.592
30	979.329	58	981.757
32	979.487	60	981.918
34	979.652	65	982.288
36	979.822	70	982.608
38	979.995	75	982.868
40	980.171	80	983.059
42	980.350	85	983.178
44	980.531	90	983.217

Free Air Correction for Altitude

Altitude, m	Correction, cm/sec ²
200	-0.0617
300	-0.0926
400	-0.1234

500	-0.1543
600	-0.1852
700	-0.2160
800	-0.2469
900	-0.2777

Correction Factor for Check Point Readings

1. Determine latitude and altitude. Obtain information from local geological survey office or library.
2. Find the acceleration due to gravity for sea level from its chart.
3. Subtract the free air correction for altitude from its chart.
4. Divide the result calculated in step 3 by the standard gravitational factor 980.665cm/sec/sec.
5. Multiply the check point in the calibration charts by the factor calculated in step 4 to obtain the corrected check point readings while using the original weight.

Correction Factor for Weights

1. Determine latitude and altitude. Obtain information from local geological survey office or library.
2. Find the acceleration due to gravity for sea level from its chart.
2. Subtract the free air correction for altitude from its chart.
3. Divide the result, calculated in step 3, by the standard gravitational factor 980.665 cm/sec/sec.
4. Calculate the reverse of the calculation in step 4 by dividing it into 1.
5. Multiply the weight given for each check point in the calibration charts by the inverse factor, calculated in step 5, and use this corrected weight with the original check point readings.

CHAPTER 6

Manual Loader (2000-600-02)

The 2000-600-02 Manual Loader is designed as an integral component of the CDI **SURETEST** Torque Calibration System providing a precision output torque of up to 2000 ft lb while requiring only 8 ft lb input.

Application

The loader is a laboratory grade instrument used for testing and calibrating all torque wrenches, drivers, torque multipliers, non-impact pneumatic and electric nut runners

Power

To activate the limit solenoids that protect the transducers from overload, the loader requires AC power, 115/230VAC, 50 to 60 Hz, 1.0 amps.

WARNING

Do not use this equipment with the power off. Always turn on the *Suretest* Base Unit and loader so the torque and load values are indicated on the display. The safety relays only work when the power is on.

Transducer Rotation

The manual hand crank provides up to 20° of transducer rotation in both clockwise (CW) and counter clockwise (CCW) directions.

***SURETEST* Torque Calibration System**

Components included in System are:

- 5000-ST Base Unit (Suretest)
- 2000-600-02 Loader, and
- 2000-100-02 Roll Cabinet.

When the 2000-600-02 Manual Loader interfaces with the **5000-ST** Base Unit and the ***SURETEST*** series of torque transducers, the ***SURETEST*** Torque Calibration system provides precision loading, monitoring and data acquisition of torque, within $\pm 0.25\%$ accuracy.

System capabilities include, data storage, retrieval, statistical analysis and automatic downloading to a printer or computer.

Torque transducers, purchased separately, are available in ranges from 15-200 in oz, to 200-2000 ft lb. The ***SURETEST*** Torque Calibration system features accessory calibration equipment including precision torque bars, certified weights, calibration mounts and stands and torque multipliers.

The 2000-600-02 includes a CDI roll cabinet, part number 2000-100-02, with heavy duty casters and nine drawers with ball bearing slides for transducer and calibration equipment storage. An extendable swivel indicator stand accepts mounting of the ***SURETEST*** Base Unit for operator convenience.

Functional Description

This section describes major hardware components of the torque tester, including the:

- Torque tester calibrator,
- 2000-600-02 Manual Loader,
- Loader rear panel controls,
- Ball handle adaptor,
- 4-in-1 transducer (accessory), and
- Extension arm (accessory).

Torque Tester/Calibrator

The 2000-600-02 Manual Loader mounts on a CDI roll cabinet, part number 2000-100-02. An indicator stand mounts onto the loader.

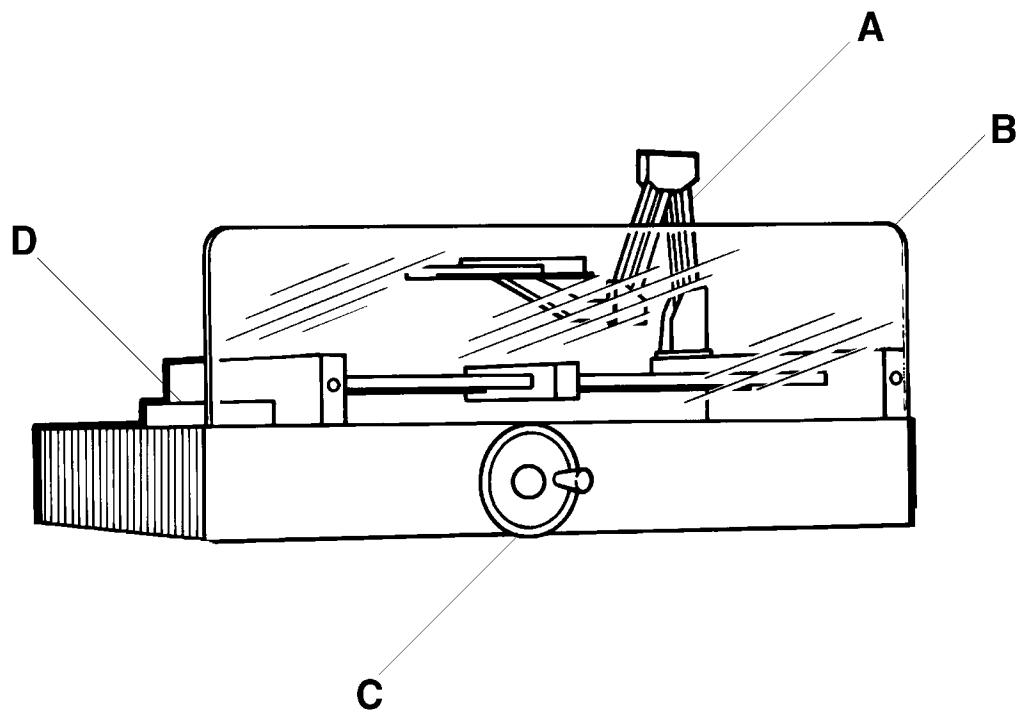

Figure 6-1: 2000-600-02 Manual Loader

- A- Indicator Stand
- B- Safety Shield
- C- Hand Crank
- D- Transducer Mounting

Use the 2000-600-02 Manual Loader to test torque wrenches. Refer to Figure 6-2 for an exploded view of the Loader and components.

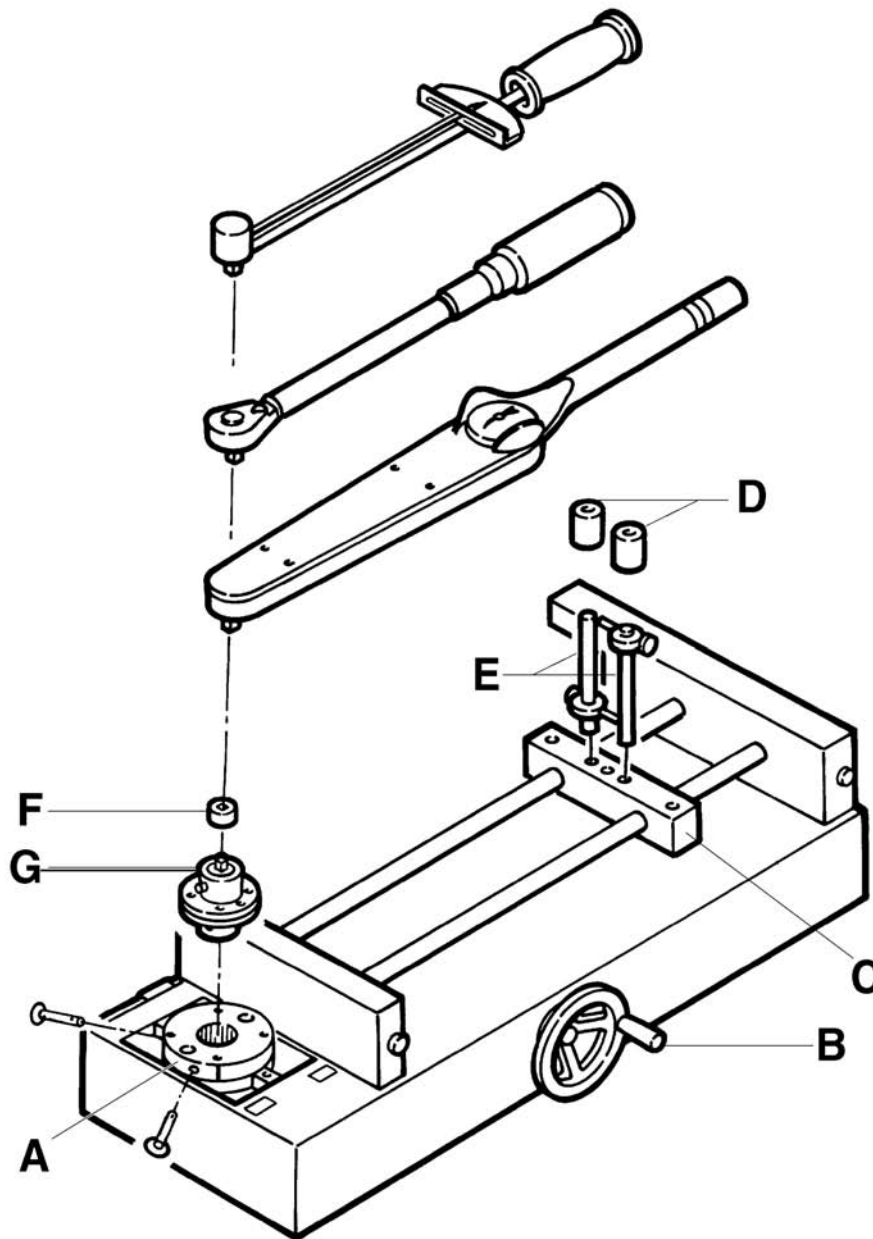

Figure 6-2: 2000-600-02 Manual Loader, Exploded View

A- Transducer Mounting

A transducer facilitates the low-to-high ranges of the wrench under test. The transducer must be installed into the loader by lining up the red mark with the "TORQUE" label on the loader and securing it using two quick release pins.

IMPORTANT

The connector on single transducer cables contains the EEPROM calibration memory chip. Never attempt to remove the connector from the transducer.

B- Hand Crank

Turn hand crank on the loader to apply torque. 2000 ft lbs of torque are generated with only 8 ft-lbs of manual torque applied.

C- Reaction Block

The reaction block is positioned so that the reaction pins straddle the wrench handle at the hand hold position specified on the wrench.

D- Linear Bearings

May be slipped over the reaction pins to reduce friction when testing very small or high resolution electronic wrenches.

E- Reaction Pins

Hold the reaction block in place.

IMPORTANT

Adjustable stops on the reaction pins may be raised or lowered to level the wrench prior to loading. Do not place a second stop above the wrench handle. It is normal for the wrench handle to rise as it levels itself under load.

F- Drive Adaptor

A drive adaptor couples the wrench to the transducer. Low torque *SURETEST* series transducers use an internal-internal drive adaptor and high torque *SURETEST* transducers may use an adaptor/reducer.

G- Transducer (Accessory)

The loader accepts all *SURETEST* series single transducers directly. An optional 2000-400-02 4-in-1 transducer can be mounted using a 2000-500-02 adaptor kit. For more information, refer to Appendix A–Accessories.

Loader Rear Panel Controls

The 2000-600-02 Manual Loader rear panel is shown in Figure 6-3.

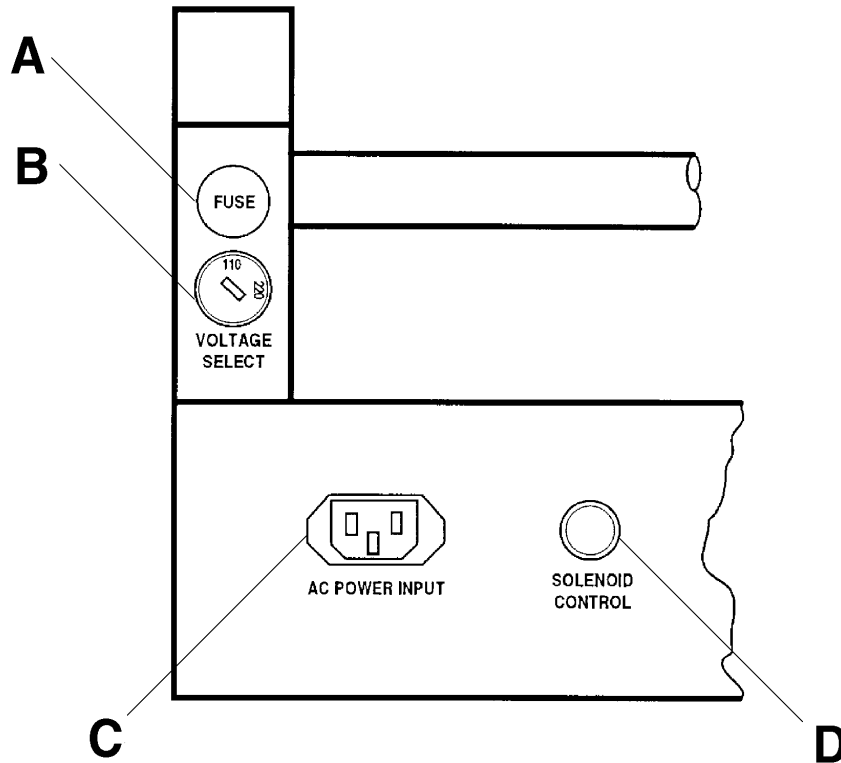

Figure 6-3: 2000-600-02 Manual Loader Rear Panel Controls

A- Fuse

The loader power supply is protected with a 1 amp slo-blow fuse.

B- Voltage Select

A selector switch allows the loader to use both 110VAC or 220VAC.

C- AC Power Input

The loader uses either 110VAC or 220VAC power. The loader connects to the *SURETEST* Base Unit by the 2000-117 cable.

D- Solenoid Control

AC power is applied to the loader to operate a pair of safety solenoids used to protect the transducers from overloading. Should the applied torque exceed 110% of the transducer capacity, in either CW or CCW directions, the Base Unit energizes the solenoids to lock the hand crank.

Ball Handle Adaptor

Wrenches featuring a ball handle are fixtured using the ball handle reaction adaptor shown in Figure 6-4. Install the adaptor onto the reaction slide using both reaction pins. Fix the adaptor height with the threaded knob.

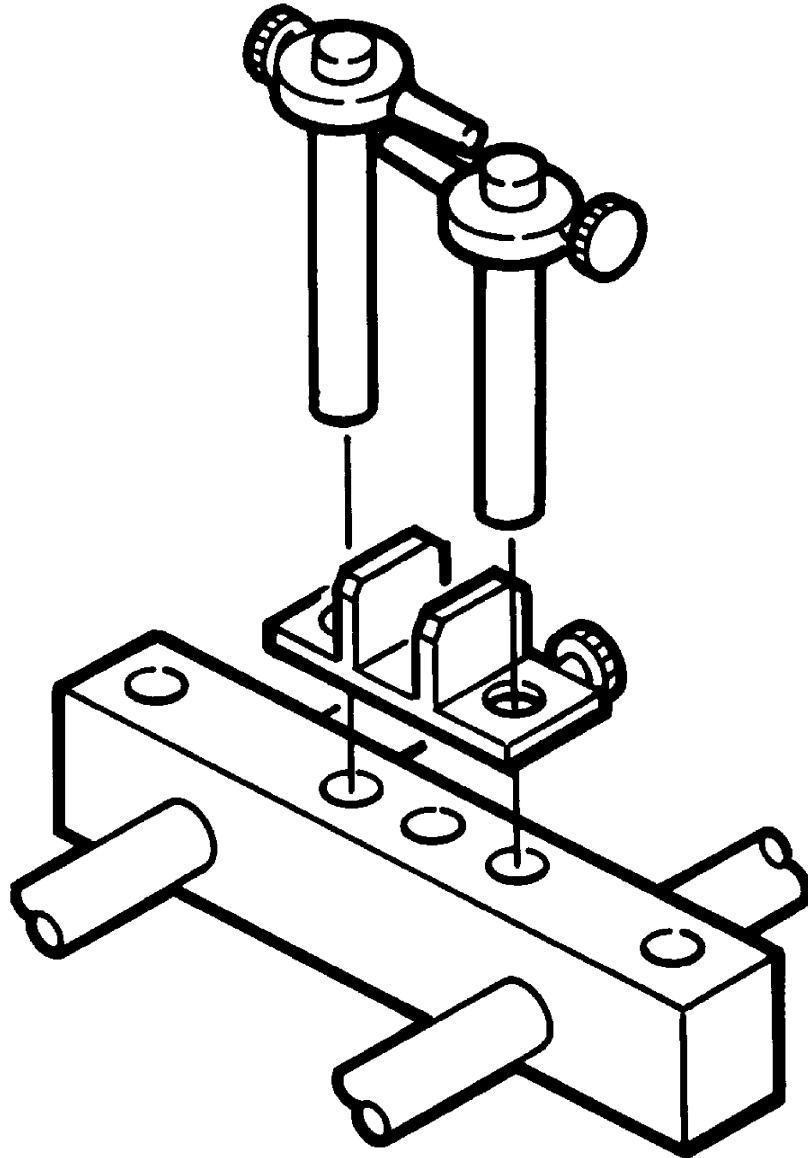

Figure 6-4: Ball Handle Adaptor

4-in-1 Transducer (Accessory)

The 4-in-1 transducer is mounted to the loader using the standoff fixture and bracket assembly as shown in Figure 6-5.

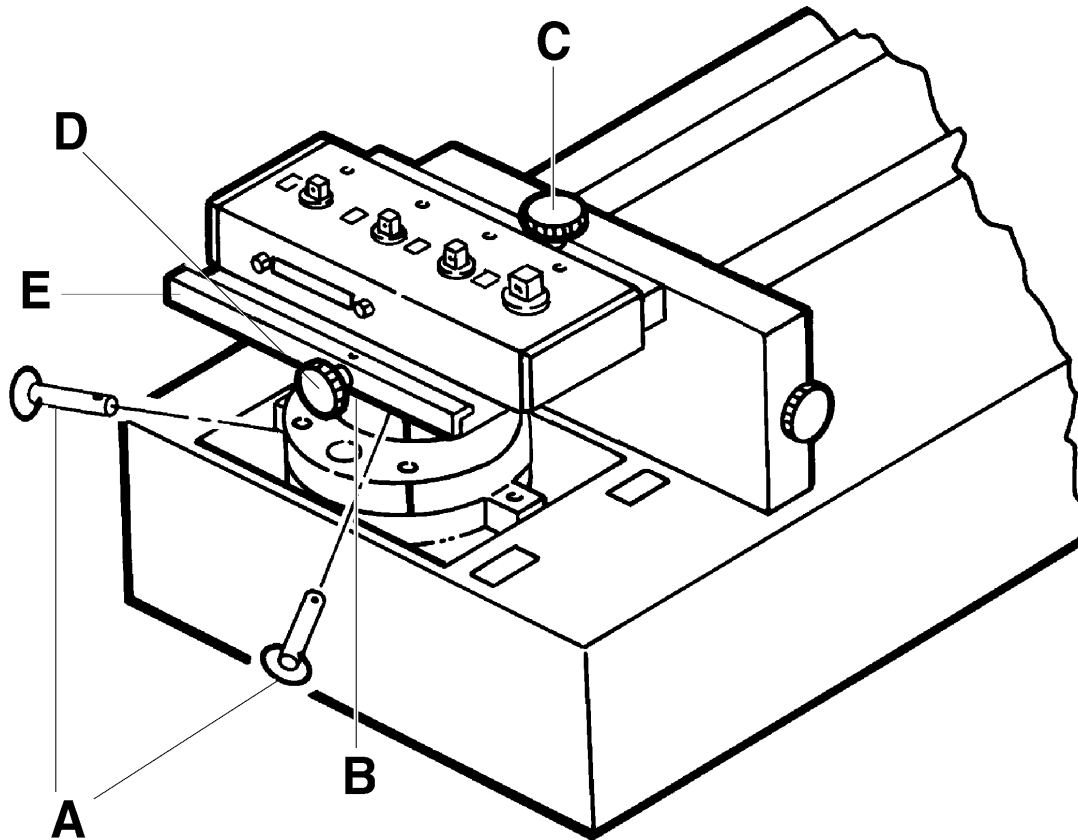

Figure 6-5: 4-in-1 Transducer on 2000-600-02 Manual Loader

A- Quick Release Pins

Four quick release pins must be installed. The first two secure the standoff fixture to the loader and the second two lock the adaptor to the transducer bracket.

B- Loader Standoff (under bracket)

The standoff and bracket must be installed into the loader by lining up the holes of the standoff to the holes of the loader.

C & D- Bracket Knobs

Two knobs on the bracket are used to align the selected transducer over the loader drive. Tighten the left knob (D) first, then the top knob (C). The wrench or driver to be tested is then coupled to the selected transducer using an internal-internal adaptor.

E- 4-in-1 Adapter Bracket

Holds the 4-in-1 transducer horizontal to the loader.

Extension Arm (Accessory)

The 2000-600-02 Manual Loader accepts torque wrenches up to 80" in length. The extension arm is attached as shown in Figure 6-6. A quick release pin is used at the end of the arm to capture the reaction pin slide assembly.

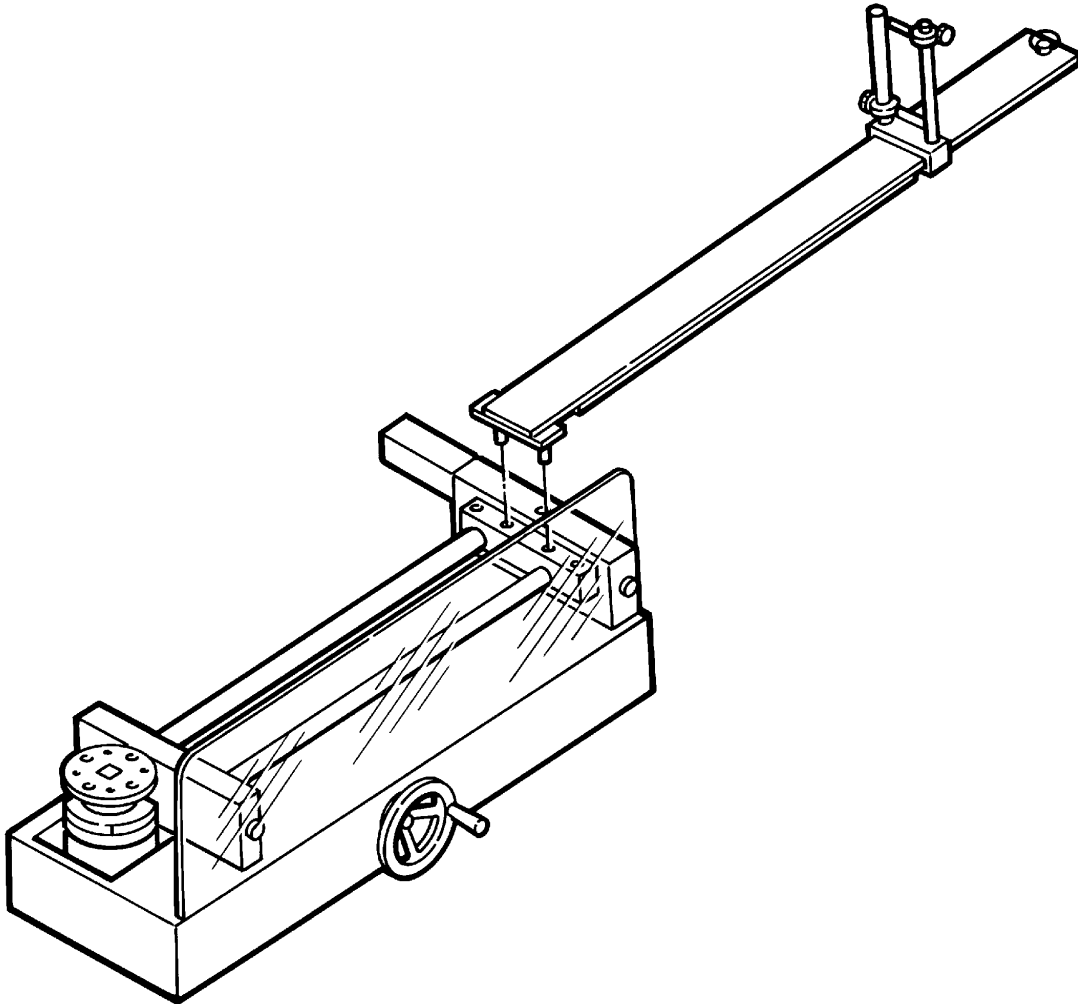

Figure 6-6: 2000-600-02 Manual Loader Extension Arm

Types of Loader Testing

Torque Driver Testing

An accessory torque screwdriver testing kit, 2000-750-02, is available for use in testing or calibrating most torque screwdrivers and "T" handled drivers. In addition to providing perfect driver-transducer alignment, it allows the use of the 2000-600-02 loader crank for precision torque application.

Certain torque screwdrivers, "T" handled drivers, electric or pneumatic nut runners, and non-impact power tools must be tested by hand. Double check to be sure that the transducer you choose is capable of handling the maximum torque that you will apply. Hold the tool exactly in line with the transducer drive while testing. Off-axis side loading may compromise the test or calibration of the tool.

Torque Multiplier Testing

The 2000-600-02 Manual Loader and *SURETEST* series transducers can be configured to test certain torque multipliers. *SURETEST* also provides measurement, display, storage and statistical analysis of multiplier output torque to 2,000 ft lbs.

In practice, the multiplier is attached to the loader using custom fixturing. The operator provides input torque with an appropriate wrench, breaker bar or the multiplier's integral hand crank.

Various mounting fixtures, adaptors, reaction stops and pins are available for testing the most common torque multipliers. Ask your CDI sales representative for design assistance.

Appendix A

Accessories

This appendix contains information on replacement parts and accessories that are available from *Consolidated Devices, Inc.*, 1-800-525-6319.

Refer to Figure A-1, below, for drawer and cutout arrangement information.

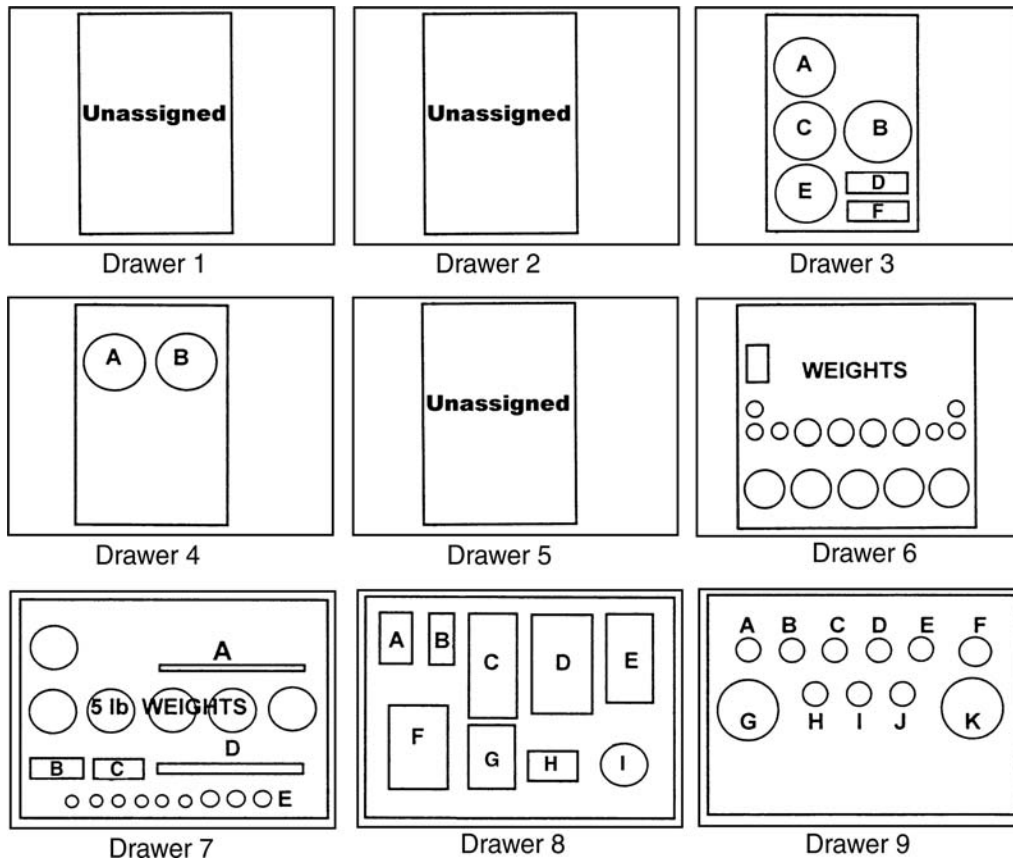

Figure A-1: Roll Cabinet Drawer Arrangement

SURETEST Torque Calibration System Components and Inventory Control

Component	Description	Drawer-Cutout
2000-100-02* Roll cabinet		
2000-100-2	Foam insert	6
2000-100-3	Foam insert	7
2000-100-4	Foam insert	8
2000-100-5	Foam insert	9
2000-100-7	Foam insert	3
2000-100-8	Foam insert	4
2000-600-02 Manual torque loader		
2000-600-10	Loader	
2000-560	Plexiglass safety shield	
2000-111-0	Indicator stand	
2000-173-1	Reaction pin assembly	8-C
2000-173-2	Reaction pin assembly	8-C
343-50-02	Standoff fixture	9-A
2000-173-11	(2) Linear ball bearing	
2000-173-6	Reaction ball handle adaptor	8-B
QC2I75**	Torque wrench	7-D
QJ024**	3/4" Open end adaptor	7-B
QIJR50**	3/8" Interchangeable ratchet head	7-C
FA12E**	3/8" x 3/8" Hex driver bit	7-C
2000-114	110VAC Power cord	3-D
2000-118	220VAC Power cord - Europe	
2000-119	220VAC Power cord - Australia	
2000-120	220VAC Power cord - Great Britain	
2000-195-12	Quick Release (2)	8-I
9502-610-02 Digital torque indicator kit		
2000-110-01	Base Unit	
2000-114	110VAC Power cord	3-F
2000-118	220VAC Power cord - Europe	3-F
2000-119	220VAC Power cord - Australia	3-F
2000-120	220VAC Power cord - Great Britain	3-F
2000-116	Cable, Indicator to transducers	3-B
2000-117	Cable, Base Unit to loader	3-E

*The 2000-100-02 roll cabinet is fitted with 1" thick foam inserts for storage and effective tool control. Storage space is also available for calibration hangers, torque arms and small weights.

**Used for calibration plate and internal drive plate installation on the 2000-13-02 and 2000-14-02 transducers. Item is not available from Consolidated Devices, Inc.

Optional Transducers and Accessories

<i>Component</i>	<i>Description</i>	<i>Drawer-Cutout</i>
2000-5-02		
1/4" ext. drive	15-200 in oz transducer	9-B
342-40	1/4" internal adaptor	7-E
2000-6-02		
1/4" ext. drive	4-50 in lb transducer	9-C
342-40	1/4" internal adaptor	7-E
2000-65-02		
1/4" ext. drive	15-150 in lb transducer	9-D
342-40	1/4" internal adaptor	7-E
2000-7-02		
3/8" ext. drive	30-400 in lb transducer	9-E
342-41-2	3/8" internal adaptor	7-E
2000-8-02		
3/8" ext. drive	80-1000 in lb transducer	9-F
342-41-2	3/8" internal adaptor	7-E
2000-10-02		
1/2" ext. drive	10-125 ft lb transducer	9-H
65-26-3	1/2" internal adaptor	7-E
2000-11-02		
1/2" ext. drive	20-250 ft lb transducer	9-I
65-26-3	1/2" internal adaptor	7-E
2000-12-02		
3/4" ext. drive	60-600 ft lb transducer	9-J
65-78-2	3/4" internal adaptor	7-E
2000-13-02		
1" int. drive	100-1000 ft lb transducer	9-G or 4-A
2000-226-2	1"-3/4" reducer	7-E
2000-14-02		
1" int. drive	200-2000 ft lb transducer	9-K or 4-B
2000-226-2	1"-3/4" reducer	7-E
2000-400-02		
4-in-1 transducer kit		
343-4-1	Multiple transducer	8-E
	1/4" ext. drive, 4-50 in lb	
	3/8" ext. drive, 30-400 in lb	
	3/8" ext. drive, 80-1000 in lb	
	1/2" ext. drive, 20-250 ft lb	
342-40	1/4" internal adaptor	7-E
342-41-1	1/4"-3/8" internal adaptor	7-E
342-41-2	3/8" internal adaptor	7-E
65-26-3	1/2" internal adaptor	7-E
343-25	Right angle mounting bracket	8-E
2000-500-02		
4-in-1 transducer adaptor kit		
2000-195-13	Quick release pin (2)	8-I
S343-500-0	Bracket assembly	8-D

Component Description

Drawer-Cutout

2000-550-02	Extension arm kit, for up to 80" wrenches	
2000-550-108	Arm	
2000-550-115	Reaction pin slide block assembly	8-F
2000-195-1	Retention pin	8-I
2000-50-1	Cable, Indicator to PC	3-C
2000-50-2	Cable, Indicator to serial printer	3-A
2000-900-121	Cable, smart cable replacement	
2000-750-02	Torque screwdriver testing kit	
900-0	Joint rate simulator; 50 in lb max, 1/4" internal square drive for use on 2000-6-02 transducer	
900-2-0	Joint rate simulator; 400 in lb max, for use on 2000-7-02 transducer	
900-3-0	Joint rate simulator; 1000 in lb max, for use on 2000-8-02 transducer	

Calibration Accessories

Calibration of the 2000-610-02 Indicator and *SURETEST* series transducers is recommended at least every 1 year.

<i>Component</i>	<i>Description</i>	<i>Drawer-Cutout</i>
2000-250-02	Calibration stand kit	
2000-250-0	Stand	
2000-150-02	Transducer mounting block	
2000-152-3	3/8" Square drive adaptor	7E
S2000-221-0	1-1/4" Square drive adaptor	7E
2000-154-8	1-1/4" - 3/4" Drive reducer	7E
2000-320-0	200 in oz - 2000 ft lb Weight Kit For This Kit Calibration Equipment	
Hangers		
2000-151-4	" S " Hook	7-A
2000-301	1/2 lb Weight hanger	7-A
2000-304-0	7.5 lb Weight tray	7-A
2000-302-0	15 lb Weight tray	7-A
2000-303-0	50 lb Weight tray	7-A
Torque Arms		
2500-50-0	2.5" Radius wheel	
2000-151-0	5" Radius wheel	
2000-152-0	10" Radius butterfly	
2000-154-0	40" Calibration arm	
Weights		
2500-310-1	0.3 oz Hook (1)	6
2500-310-2	0.5 oz Hook (1)	6
2000-310-2	2 oz Bob (1)	6
2000-310-3	4 oz Bob (1)	6
2000-300-2	1/2 lb Disk (1)	6
2000-300-3	1 lb Disk (2)	6
2000-300-4	2 lb Disk (4)	6
2000-300-5	5 lb Disk (6)	7
2000-300-6	10 lb Block (4)	
2000-300-7	20 lb Block (4)	
2000-300-8	50 lb Block (4)	
2000-321-0	200 in oz - 250 ft lb Weight Kit For This Kit Calibration Equipment	
Hangers		
2000-301	1/2 lb Weight hanger	
2000-304-0	7.5 lb Weight tray	
2000-302-0	15 lb Weight tray	
Torque Arms		
2000-50-02	2.5" Radius wheel	
2000-151-0	5" Radius wheel	
2000-152-0	10" Radius butterfly	

Component	Description	Drawer-Cutout
Weights		
	2500-310-1	0.3 oz Hook (1) 6
	2500-310-2	0.5 oz Hook (1) 6
	2000-310-2	2 oz Bob (1) 6
	2000-310-3	4 oz Bob (1) 6
	2000-300-2	1/2 lb Disk (1) 6
	2000-300-3	1 lb Disk (2) 6
	2000-300-4	2 lb Disk (4) 6
	2000-300-5	5 lb Disk (6) 7
	2000-300-6	10 lb Block (4)
	2000-300-7	20 lb Block (4)
	2000-300-8	50 lb Block (4)
2000-322-0	600 in oz - 2000 ft lb Weight Kit For This Kit Calibration Equipment	
Hangers		
	2000-302-0	15 lb Weight tray
	2000-303-0	50 lb Weight tray
Torque Arms		
	2000-154-0	40" Calibration arm
Weights		
	2000-300-3	1 lb Disk (1) 6
	2000-300-4	2 lb Disk (1) 6
	2000-300-5	5 lb Disk (2) 7
	2000-300-6	10 lb Block (4)
	2000-300-7	20 lb Block (5)
	2000-300-8	50 lb Block (8)